

Date: 2008-11-20

Residential sprinkler systems – Part 1: Design, installation and maintenance

(DK) Boligsprinkling – Projektering, installation og vedligeholdelse

(IS) Heimilisúðakerfi – Hönnun, uppsetning og viðhald

(NO) Boligsprinkler – Dimensjonering, installering og vedlikehold

(SE) Boendesprinkler – Utförande, installation och underhåll

(SF) Asuntosprinklerilaitteistot – Suunnittelu, asentaminen ja kunnossapito

Contents

	page
1 Scope	6
2 Normative references	7
3 Terms and definitions	8
4 Contract planning and documentation	10
4.1 General	10
4.2 Preliminary or estimating stage	10
4.3 Design stage	11
5 Extent of sprinkler protection	15
5.1 Buildings and areas to be protected	15
5.2 Fire resistant separation	16
6 Classification of occupancies	16
6.1 Building types	16
7 Hydraulic design and pipe layout	17
7.1 Design criteria	17
7.2 Sprinkler discharge pressure	18
7.3 Locations of the area of operation	19
7.4 Pipe layout	19
8 Water supplies	21
8.1 Water supply	21
8.2 Maximum water pressure	21
8.3 Housing of equipment for water supplies	21
8.4 Test facility devices	22
9 Type of water supply	23
9.1 General	23
9.2 Town mains	23
9.3 Storage tanks	23
9.3.4 Reduced capacity tanks	24
9.4 Pressure tanks	24
10 Pumps	24
10.1 General for all building types	24
10.2 Compartments for pumpsets, type 2 buildings	25
10.3 Compartments for pumpsets, type 3 buildings	25
10.4 Temperature requirements, all building types	25
10.5 Valves and accessories, all building types	25
10.6 Suction conditions, all building types	26
10.7 Performance characteristics, all building types	28
10.8 Electrically driven pumpset, all building types	29
10.9 Diesel engine driven pumpset, all type of buildings	30
11 Installation type and size	34
11.1 Wet pipe installations	34
11.2 Dry pipe installations	35
11.3 Pre-action installations	35
12 Spacing and location of sprinklers	35
12.1 General	35
12.2 Wardrobes	36
12.3 Spacing of Residential and Quick Response Extended Coverage sprinkler	36
12.4 Location of Residential and Quick Response Extended Coverage sprinklers in relation	

to walls and ceilings.....	37
12.5 Deflector position of Residential and Quick Response Extended Coverage sprinkler	37
12.6 Obstructions in relation to Residential and Quick Response Extended Coverage sprinklers .	38
13 Pipe sizing and layout.....	42
14 Sprinkler design characteristics and uses	42
14.1 General	42
14.2 Sprinkler types and application	42
14.3 Sprinkler nominal operating temperatures.....	42
14.4 Sprinkler rosettes	43
15 Valves	43
15.1 Control valve set.....	43
15.2 Stop valves.....	44
15.3 Drain requirements.....	44
15.4 Test valves	45
15.5 Pressure gauges.....	45
16 Alarms and alarm devices	46
16.1 General	46
16.2 Alarms and alarm devices, type 2 and 3 buildings	46
16.3 Electrical water flow and pressure switches	46
16.4 Alarm connection to alarm receiving centre	46
17 Pipework.....	48
17.1 Pipe system.....	48
17.2 Pipe supports.....	48
18 Signs, notices, and information.....	48
18.1 Block plan	48
18.2 Signs and notices.....	49
19 Commissioning and acceptance tests and periodic inspection	50
19.1 Commissioning tests	50
19.2 Completion certificate and documents	50
20 Inspection, testing and maintenance	51
20.1 General	51
20.2 Precautions while carrying out work.....	51
20.3 Requirements for type 2 buildings	51
21 Third party inspection.....	52
21.1 General	52
21.2 Inspection procedures for type 2 and 3 buildings	52
Annex A (normative) Zoning.....	53
A.1 General	53
A.2 Requirements for zoned installations	53
Annex B (normative) Sprinkler systems monitoring.....	54
B.1 General	54
B.2 Functions to be monitored	54
Annex C (normative) Transmission of alarms	56
C.1 Functions to be monitored	56
C.2 Alarm levels	56
Annex D (informative) Precautions and procedures when a system is not fully operational.....	58
D.1 Minimizing the effects.....	58
D.2 Planned shut-down	58
D.3 Unplanned shut-down.....	58
D.4 Action following sprinkler operation.....	59
Annex E (normative) Inspection of pipes and sprinklers	60
Annex F (informative) New technology.....	61

Foreword

This standard (prSS 88 30 01 (INSTA 900-1)) has been prepared by Nordic Residential Fire Sprinkler Guidelines Working Group 1. The members of the group has been:

Tore Aarnes, FNH/FG, Norway

Hildegunn Borge, FNH/FG, Norway

Henrik Bygbjerg, Dansk Brand- og sikringsteknisk Institut, Denmark

Astvaldur Eiriksson, Eldvarnarþjónustan, Iceland

Nick Groos, liason from European Fire Sprinkler Network

Gudmundur Gunnarsson, Brunamalastofnun, Iceland

Jens Hjort, Brandskyddsföreningen, Sweden (secretary)

John-Erik Holmli, Brannteknisk forening, Norway (chairman)

Gösta Holmstedt, Sprinklerfrämjandet, Sweden

Jens Erik Lauritzen, Tyco IS, Denmark

Per Arne Lindvik, Brannteknisk forening, Norway

Finn Masseson, Dansk Brand- og sikringsteknisk Institut, Denmark

Kirsi Rajaniemi, Inrikesministeriet, Finland

Martin Svensson, VVS företagen Sprinklersektionen, Sweden

Each country shall translate and publish this document, as a national standard or as an otherwise recognised document. This shall be an identical text. Until the document has been translated the English language version may be used.

Introduction

An automatic residential sprinkler system is designed to detect a fire and extinguish it with water in its early stages or hold the fire in check so that evacuation can be completed safely. The residential sprinkler system will also hold the fire in check so that the possibility of extinguishment by other means will increase.

A residential sprinkler system consists of a water supply, a main control valve and a pipe array fitted with sprinkler heads. The sprinkler heads are fitted at specified locations at the roof, ceiling or walls.

The sprinklers operate at predetermined temperatures to discharge water over the affected part of the area below. The flow of water initiates a fire alarm. The operating temperature is generally selected to suit ambient temperature conditions.

Only sprinklers in the vicinity of the fire, i.e. those which become sufficiently heated, operate.

The residential sprinkler system is intended to extend throughout the premises with only limited exceptions.

It should not be assumed that the provision of a residential sprinkler system entirely obviates the need for other means of detecting and fighting fires and it is important to consider the fire precautions in the occupancy as a whole.

Structural fire resistance, escape routes, smoke alarms, fire alarm systems, provision of portable fire extinguishers, training and information all need consideration.

It is essential that residential sprinkler systems should be properly maintained to ensure operation when required. This routine is liable to be overlooked or given insufficient attention. It is, however, neglected at peril to the lives of occupants of the premises and at the risk of crippling financial loss. The importance of proper maintenance cannot be too highly emphasized.

When residential sprinkler systems are out of service extra attention should be paid to fire precautions and the residents informed.

This guideline is intended for use by those concerned with purchasing, designing, installing, testing, inspecting, approving, operating and maintaining automatic residential sprinkler systems, in order that such equipment will function as intended throughout its life.

This guideline is intended only for fixed residential fire sprinkler systems in buildings on land, and it is a basic assumption that this guideline is for the use of companies employing personnel competent in the field of application with which it deals. Only trained and experienced personnel should undertake the design, installation and maintenance of residential sprinkler systems. Similarly, competent technicians should be used in the installation and testing of the equipment.

This guideline does not necessarily cover all legislative requirements.

1 Scope

This guideline specifies requirements and gives recommendations for the design, installation and maintenance of fixed residential fire sprinkler systems in buildings, or part of buildings, intended for residential occupancies, such as

- private homes (one and two family dwellings, row houses, vacation homes etc),
- apartments, flats,
- manufactured homes,
- care institutions (nursing homes, hospitals etc),
- hotels, motels etc,
- student housing, dormitories,
- asylum centres.

The requirements and recommendations of this guideline are also applicable to any addition, extension, repair or other modification to the residential sprinkler system.

It covers provision of water supplies, components to be used, installation and testing of the system, maintenance, and the extension of existing systems, and identifies construction details of buildings which are the minimum necessary for satisfactory performance of residential sprinkler systems complying with this guideline.

The guideline is not intended to restrict new technologies or alternative arrangements, provided that an equivalent level of safety is assured.

Forms of secure accommodations such as correctional or rehabilitation facilities are not covered by this guideline.

2 Normative references

The following referenced documents are indispensable for the application of this document. For dated references, only the edition cited applies. For undated references, the latest edition of the referenced document (including any amendments) applies.

EN 54 (All parts), *Fire detection and fire alarm systems*.

EN 12259-1, *Fixed firefighting systems - Components for sprinkler and water spray systems - Part 1: Sprinklers*.

EN 12259-2, *Fixed firefighting systems - Components for sprinkler and water spray systems - Part 2: Wet alarm valve assemblies*.

EN 12259-3, *Fixed firefighting systems - Components for sprinkler and water spray systems - Part 3: Dry alarm valve assemblies*.

EN 12259-5, *Fixed firefighting systems - Components for sprinkler and water spray systems - Part 5: Water flow detectors*.

prEN 12259-12, *Fixed firefighting systems - Components for sprinkler and water spray systems - Part 12: Pumps*.

EN 12723, *Liquid pumps — General terms for pumps and installations — Definitions, quantities, letter symbols and units*.

EN 12845, *Fixed firefighting systems – Automatic sprinkler system – Design, installation and maintenance*.

EN 50342, *Lead-acid starter batteries — General requirements, methods of test and numbering*.

EN 60529, *Degrees of protection provided by enclosures (IP code) (IEC 60529:1989)*

EN 60623, *Secondary cells and batteries containing alkaline or other non-acid electrolytes - Vented nickel-cadmium prismatic rechargeable single cells (IEC 60623:2001)*.

EN 60947-1, *Low-voltage switchgear and controlgear – Part 1: General rules (IEC 60947-1:1999, modified)*.

EN 60947-4, *Low-voltage switchgear and controlgear - Contactors and motor-starters; Electromechanical contactors and motor-starters (IEC 60947-4-1:2000)*.

IEC 60331 (All parts), *Tests for electrical cables under fire conditions*

INSTA 900-2 *Residential sprinkler systems – Part 2: Requirements and test methods for sprinklers and their accompanying rosettes*

ISO 3046 (All parts), *Reciprocating internal combustion engines*.

3 Terms and definitions

For the purposes of this document the definitions in EN 12845 are valid. For terms not used in EN 12845, the following definitions apply.

3.1

actual area of coverage

$A_s = S \times D$, Method: the actual area of coverage of a sprinkler equals "S" x "D" where "S" is the distance between sprinklers on the branch lines or twice the distance to the nearest obstruction in that direction. "D" is the distance between branch lines or twice the distance to the nearest obstruction in that direction.

3.2

alarm receiving centre

a permanently manned external center from which the necessary fire fighting measures can be initiated at any time

3.3

authority

an organization or individual responsible for approving sprinkler systems, equipment and procedures, e.g. the fire and building control authorities, the fire insurers, the local water authority, other appropriate public authorities or the owner

3.4

design area of coverage

the area in m² for the sprinkler according to the manufacturer's specifications for which the sprinkler is being used

3.5

design discharge

the total flow in litres per minute from the design sprinklers at the spacing for which they are being used.

3.6

design density

the discharge from the design sprinklers, divided by the area in square metres represented by the spacing for which they are being used, expressed in units of mm/min.

3.7

design sprinklers

adjacently located sprinklers within the same residential compartment having the greatest hydraulic demand. The design sprinklers are used to determine the hydraulic design of the sprinkler system.

3.8

dwelling

any building that contains dwelling units intended to be used, rented, leased, let or hired out to be occupied for habitation purposes.

3.9

dwelling unit

the area in a building arranged for the purposes of habitation of one or more individuals containing sleeping, living, cooking and sanitary facilities.

3.10

flat smooth ceiling

a continuous ceiling in a single plane, free from obstructions that could influence the discharge pattern of the sprinkler

3.11

horizontal ceiling

a ceiling with a slope not exceeding 8,5 degrees

3.12

local manned centre

an internal or external centre where alarm and fault signals can be received and from which the necessary action can be taken

3.13

manufacturer's specification

a document published by a manufacturer which is accepted by the authorities and intended to supplement this guideline with additional technical information with regards to design, installation and maintenance

3.14

multipurpose piping system

a piping system intended to serve both domestic and fire protection needs

3.15

network system

a type of multipurpose piping system, applicable for Type 1 buildings only, utilizing a common piping system supplying plumbing fixtures and fire sprinklers where each sprinkler is supplied by a minimum of three separate paths.

3.16

quick response extended coverage sprinkler

a type of spray sprinkler with maximum coverage areas as specified in paragraph 7.2.3. The sprinkler may be of either upright, pendent or sidewall type. They have a quick response element as specified in EN 12259-1

3.17

quick response spray sprinkler

a spray sprinkler with a quick response element according EN12259-1, either upright, pendent or sidewall type

3.18

quick response conventional sprinkler

a conventional sprinkler with a quick response element according EN12259-1

3.19

residential compartment

a space completely enclosed by walls and a ceiling. Openings to an adjoining space are allowed, provided the openings have a minimum lintel depth of 210mm from the ceiling. The total width of openings in a single wall shall not exceed 2.4 m. A single opening of 900mm or less in width without a lintel is allowed when there are no other openings to adjoining spaces.

3.20

residential sprinkler

a type of sprinkler having a thermal element with an RTI of 50 (meters-seconds)^{1/2} or less that is specifically investigated for its ability to enhance survivability in the room of fire origin and passed the tests according to NRFSG 45-2.

3.21

sloped ceiling

a ceiling with a slope exceeding 8,5 degrees

3.22

sprinkler

a fire control device that operates automatically when its heat-activated element is heated to its thermal rating or above, allowing water to discharge over a specified area.

3.23

standard coverage dry sprinkler

a fire control device comprising a pendent, sidewall or upright spray sprinkler or conventional sprinkler and a dry pipe with a valve, at the head of the pipe in a heated area, held closed by a device maintained in position by the sprinkler head valve located in an unheated area.

3.24

temperature rating, ordinary

a temperature rating of between 57°C and 77°C.

3.25

temperature rating, intermediate

a temperature rating of between 79°C and 107°C.

3.26

third party

a person or body that is independent of the person or organization that provides the system and of user interests in that system

NOTE Criteria for the independence of bodies are provided in the International Standards and guides applicable to their activities

3.27

wardrobe

any enclosure with an area greater than 2 m² containing clothes, linen or other combustible materials

4 Contract planning and documentation

4.1 General

The information specified in this clause shall be provided to the user or owner as appropriate. All drawings and information documents shall carry the following information:

- a) the name of the user and the owner, where known;
- b) the address and location of premises;
- c) the type of occupancies found in each part of the building;
- d) the name of the designer;
- e) the name of the person responsible for checking the design, who shall not be the designer;
- f) date and number of issue.

4.2 Preliminary or estimating stage

At least the following information shall be provided:

- a) a block plan of the premises showing:
 - 1) the type of building (see chapter 6);
 - 2) the extent of the system with details of any unprotected areas;
 - 3) location of control valve set(s);
 - 4) location of zone stop valves (if applicable)
 - 5) a cross-section of the full height of the building(s) showing the height of the highest sprinkler above a stated datum level;
- b) general information of the water supplies, which if town main shall include pressure flow data, with the date and time of test, and a plan of the test site; and
- c) description of any deviations from the requirements of this guideline and the reasons why.

4.3 Design stage

4.3.1 General

The information provided shall include a summary schedule (see 4.3.2), complete working drawings of the sprinkler installation(s) (see 4.3.3) and details of the water supplies (see 4.3.4).

4.3.2 Summary schedule

The summary schedule shall give the following information:

- a) the name of project;
- b) all drawings or document reference numbers;
- c) the type(s) of installation(s) and the nominal diameter(s) of each control valve set;
- d) the number or references of each control valve set in the system;
- e) the number of sprinklers on each control valve set;
- f) the piping volume in the case of dry installations;
- g) the height of the highest sprinkler on each control valve set;
- h) a statement from the designer that the system will be designed and installed in accordance with this guideline giving details of any deviations from its requirements and the reasons why;
- i) a list of the components suitable for the system, each identified by supplier's name and model/reference number.

4.3.3 Installation layout drawings

4.3.3.1 General

Layout drawings shall include the following information:

- a) the type of building (see chapter 6);
- b) plan and cross sections showing construction details of floors, ceilings, roofs, exterior walls and walls separating sprinklered and non-sprinklered areas;
- c) the following information of each sprinkler:
 - temperature rating,
 - K-factor
 - response type
 - orientation;

and for each residential sprinkler also the following information:

- area of coverage,
- pressure and flow requirements;

NOTE The manufacturer's SIN-number includes information regarding K-factor, response type, orientation and type of sprinkler

- d) the location of access to and the type of control valve sets;
- e) the location and details of any water flow, and air or water pressure alarm switches;

- f) the location and size of any subsidiary valves, subsidiary stop valves and drain valves;
- g) a schedule listing the numbers of sprinklers and the area of protection;
- h) the location of all test valves;
- i) the location and details of any alarm panel;
- j) the location of all concealed piping;
- k) a key to the symbols used.

4.3.3.2 Calculation

The following shall be given, with detailed calculations, either on purpose designed work sheets or as a computer printout:

- a) the hydraulic calculation program name and version number;
- b) the date of the worksheet or print-out;
- c) the actual internal diameters of all pipes used in the calculation;
- d) for each design area of operation;
 - 1) the area identification;
 - 2) the type of building (see Chapter 6);
 - 3) the specified design density in millimetres per minute;
 - 4) the assumed maximum area of operation (area of operation) in square metres;
 - 5) the number of sprinklers in the area of operation;
 - 6) the sprinkler nominal orifice size in millimetres;
 - 7) the maximum area covered per sprinkler in square metres;
 - 8) detailed and dimensioned working drawings showing the following:
 - i) the node or pipe reference scheme used to identify pipes, junctions, sprinkler heads and fittings which need hydraulic consideration;
 - ii) the position of the sprinkler requiring the greatest hydraulically demand;
 - iii) the sprinklers upon which the design density is based;
 - iv) the height above datum of each point of identified pressure value.
- e) for each operating sprinkler:
 - 1) the sprinkler node or reference number;
 - 2) the nominal K factor (see EN 12259-1);
 - 3) the flow through the sprinkler in litres per minute;
 - 4) the inlet pressure to the sprinkler or sprinkler assembly in bar.

- f) for each hydraulically significant pipe:
- 1) pipe node or other reference number;
 - 2) nominal bore in millimetres;
 - 3) the Hazen-Williams constant;
 - 4) flow in litres per minute;
 - 5) velocity in metres per second;
 - 6) length in metres;
 - 7) numbers, types and equivalent length in metres of fittings and components;
 - 8) static head change in metres;
 - 9) pressures at inlet and outlet in bar;
 - 10) friction loss in bar;
 - 11) indication of flow direction.

4.3.4 Water supply

4.3.4.1 Water supply drawings

The drawings shall show pipework from the water supply to the control valve set. A key to the symbols shall be included. The position and type of stop and non-return valves and any pressure reducing valves, water meters, back flow preventers and any connections supplying water for other services, shall be indicated.

4.3.4.2 Hydraulic calculation

A hydraulic calculation shall show that the minimum water supply characteristics are capable of providing the required pressure and flow at the control valve set.

4.3.4.3 Town main

Where a town main forms the supply or provides infill to a reduced capacity storage tank, the following details shall be given:

- a) the nominal diameter of the main;
- b) whether the main is double-end fed or dead-end; if dead-end, the location of the nearest double-end fed main connected to it;
- c) the pressure/flow characteristic graph of the town main determined by a test at a period of peak demand. At least three pressure/flow points shall be obtained. The graph shall be corrected for friction losses and static head difference between the test location and either the control valve 'C' gauge or the suction tank infill valve, as appropriate;
- d) the date and time of the town main test;
- e) the location of the town main test point relative to the control valve set.
- f) a pressure/flow characteristic graph indicating the available pressure at any flow up to the maximum flow demand;
- g) the demand pressure/flow characteristic graph for each installation for the hydraulically most demanding sprinklers area of operation with pressure taken as at the control valve 'C' pressure gauge.

4.3.4.4 Automatic pump set

The following details of each automatic pump set shall be provided:

- a) a pump characteristic curve for low water level 'X' showing the estimated performance of the pump or pumps under installed conditions at the control valve 'C' gauge.
- b) the pump manufacturer's data sheet showing the following:
 - 1) the generated head graph;
 - 2) the power absorption graph;
 - 3) the net positive suction head (NPSH) graph;
- c) the installer's data sheet showing the pumpset installed performance pressure/flow characteristics, at the control valve 'C' gauge for normal water level and for low water level 'X' and at the pump outlet pressure gauge for normal water level;
- d) the height difference between the control valve 'C' gauge and the pump delivery pressure gauge;
- e) the available and the specified NPSH at maximum required flow;
- f) the minimum depth of water cover of submersible pumps.
- g) the most demanding sprinkler pressure/flow characteristic for the hydraulically most unfavourable and, for type 2 and type 3 buildings, the most favourable area of operation calculated at the control valve 'C' gauge.
- h) installation drawings, main electrical supply and transformer diagrams and connections for supplying the pump controller panel as well as motor, control alarm circuits and signals.

4.3.4.5 Storage tank

The following details shall be provided:

- a) the location;
- b) the total volume of the tank;
- c) the effective capacity of the tank and duration;
- d) the inflow for reduced capacity tanks;
- e) the vertical distance between the pump centre line and the tank low water level 'X';
- f) structural details of the tank and roof;
- g) the recommended frequency of external and internal inspection;
- h) protection against freezing;
- i) low and normal water levels X and N;
- j) height of gravity tank above the highest sprinkler.

4.3.4.6 Pressure tank

The following details shall be provided:

- a) the location;

- b) the total volume of the tank;
- c) the volume of stored water;
- d) the air pressure;
- e) the height of the highest and/or hydraulically most remote sprinkler above the bottom of the tank;
- f) the vertical distance of the lowest sprinklers below the bottom of the tank;
- g) details of the means of refilling.

5 Extent of sprinkler protection

5.1 Buildings and areas to be protected

Where a building is to be sprinkler protected, all areas of that building or of a communicating building shall be sprinkler protected, except in the cases indicated in 5.1.1 and 5.1.2.

5.1.1 Permitted exceptions for type 1 buildings

Sprinkler protection may be omitted in the following cases:

- a) toilets or bathrooms less than 5 m² of non-combustible materials and which are not used to store combustible materials or are not prepared for electrical machinery such as washing machines, dryers, etc. or are equipped with any sprinkler component;
- b) unused attics;
- c) rooms that are not used for living with a fire resistant separation (see 5.2) that serves as a separate fire compartment, for example garages or boiler rooms;
- d) outdoor open balconies;
- e) crawl spaces, floor/ceiling spaces, elevator shafts, and other concealed spaces that are not used or intended for living purposes or storage.

5.1.2 Permitted exceptions for type 2 and type 3 buildings

Sprinkler protection may be omitted after due consideration of the fire load in each case:

- a) toilets or bathrooms less than 5 m² of non-combustible materials and which are not used to store combustible materials or are not prepared for electrical machinery such as washing machines, dryers, etc., or are equipped with any sprinkler component;
- b) unused attics not containing electrical machinery;
- c) rooms that are not used for living with a fire resistant separation (see 5.2) that serves as a separate fire compartment;
- d) outdoor open balconies;
- e) enclosed staircases and enclosed vertical shafts (e.g. lifts or service shafts) containing no combustible material and constructed as a fire resistant separation (see 5.2).
- f) rooms protected by other automatic extinguishing systems accepted by the authority;
- g) for type 2 buildings: crawl spaces, floor/ceiling spaces, elevator shafts, and other concealed spaces that are not used or intended for living purposes or storage;

h) for type 3 buildings: concealed spaces as specified in EN12845, see chapter 5.4.

5.2 Fire resistant separation

The separation between a sprinkler protected area and a non-protected area shall have a sufficient fire resistance as specified by the authority.

6 Classification of occupancies

6.1 Building types

The residential sprinkler system shall be designed according to the type of building to be protected. The building shall be classified as Type 1, Type 2 or Type 3 as shown in Table 1.

If an area exists within a building as defined in Table 1, and contains a hazard other than that which would typically be found in a residential occupancy, then that area shall be sprinkler protected according to EN 12845.

Table 1 – Description of types of buildings

Type of Building	Description
1	Buildings that do not permanently house people who need assistance exiting the building and can be categorized as: <ul style="list-style-type: none"> - One and two family dwellings; - Row houses having three levels above ground including the attic, and one basement level; or - Residential buildings with not more than 4 dwelling units up to a maximum of three stories in height and one basement level
2	Buildings arranged as residential occupancies up to a maximum of four stories in height and one basement level, excluding any building arranged to permanently house people who need assistance exiting the building
3	<ul style="list-style-type: none"> - Buildings, or parts of buildings, arranged to house people who need assistance exiting the building - Buildings of 5 stories in height or more, arranged as residential occupancies.

NOTE For buildings not covered by the descriptions in Table 1, the type of building should be decided by the authority.

7 Hydraulic design and pipe layout

Unless otherwise specified in this guideline, the requirements for hydraulic design and pipe layout in EN 12845 shall apply.

7.1 Design criteria

The minimum requirements for the design discharge density, the number of design sprinklers, and the duration of water supply shall be according to Table 2.

Table 2 – Minimum design criteria

Type of building	Minimum design discharge density (mm/min)	Number of design sprinklers	Minimum duration of water supply (minutes)
1	2,04	1-2 ¹⁾	10
2	2,04	1-4 ¹⁾	30
3	4,08	4	30

1) The number of design sprinklers required are defined in 7.2

This guideline defines how sprinkler systems shall be designed, installed and maintained in residential buildings conforming to local building codes. In those cases where the building does not conform to local building codes and residential sprinkler systems are prescribed to compensate for areas of non-compliance related to safety in case of fire, the minimum requirements shall be in accordance with Table 3.

Table 3 – Minimum design criteria in case of compensation for other fire protection

Type of building	Minimum design discharge density (mm/min)	Minimum number of design sprinklers	Minimum duration of water supply (minutes)
1	2,25	2	15 ²⁾
2	5	4 ¹⁾	30
3	5	4 ¹⁾	30

1) The minimum numbers of design sprinklers shall be calculated by acceptable analytic calculation methods. In any case the minimum number of design sprinklers shall not be less than 4.

2) The minimum duration of water supply shall be calculated by acceptable analytic calculation methods. In any case the duration of water supply shall not be less than 15 minutes.

7.2 Sprinkler discharge pressure

The minimum operating pressure at any sprinkler shall not be less than 0,5 bar, or according to the manufacturers specifications, whichever is greater. The maximum operating pressure at any sprinkler shall not exceed 12 bar.

7.2.1 Residential sprinklers – Type 1 Building

The sprinkler system shall be capable of providing the minimum design discharge density as specified in Table 2 or by the manufacturer's specifications at the design area of coverage for which the residential sprinkler is being used, whichever is greater for up to a maximum of 2 design sprinklers in each residential compartment. If the actual area of coverage is less than the design area of coverage, then the manufacturer's requirements for pressure and flow for the next larger design area of coverage shall be used. The greatest dimension of the actual area of coverage of each individual sprinkler cannot be any greater than the greatest dimension of the design area of coverage specified by the manufacturer for which the residential sprinkler is being used.

7.2.2 Residential sprinklers – Type 2 Building

The sprinkler system shall be capable of providing the minimum design discharge density as specified in Table 2 or by the manufacturer's specifications at the design area of coverage for which the residential sprinkler is being used, whichever is greater for up to a maximum of 4 design sprinklers in each residential compartment. If the actual area of coverage is less than the design area of coverage, then the manufacturer's requirements for pressure and flow for the next larger design area of coverage shall be used. The greatest dimension of the actual area of coverage of each individual sprinkler cannot be any greater than the greatest dimension of the design area of coverage specified by the manufacturer for which the residential sprinkler is being used.

7.2.3 Residential sprinklers – Type 3 Building

The design sprinklers shall be designated as the four sprinklers having the greatest hydraulic demand. The minimum design discharge density from each of the four design sprinklers is to be the greater of the following:

- the minimum design discharge density as specified by the manufacturer at the design area of coverage for which the residential sprinkler is being used. If the actual area of coverage is less than the design area of coverage, then the manufacturer's specifications for pressure and flow for the next larger design area of coverage shall be used. The greatest dimension of the actual area of coverage of each individual sprinkler cannot be any greater than the greatest dimension of the design area of coverage specified by the manufacturer for which the residential sprinkler is being used.
- The minimum design discharge density as specified in Table 2 over the actual areas of coverage being protected by the sprinklers.

7.2.4 Quick Response Extended Coverage sprinklers

The minimum design discharge density from each of the design Quick Response Extended Coverage sprinklers shall be the greater of the following;

- the minimum design discharge density as specified by the manufacturer at the design area of coverage for which the Quick Response Extended Coverage sprinkler is being used. If the actual area of coverage is less than the design area of coverage, then the manufacturer's requirements for pressure and flow for the next larger design area of coverage shall be used.
- The minimum design density requirements according to Table 2

The maximum protection area of coverage shall be in compliance with the manufacturer specifications. The maximum actual area of coverage of 37 m² shall never be exceeded.

7.2.5 Quick Response Spray and Quick Response Conventional sprinklers

Quick response spray and quick response conventional sprinklers shall be permitted to be installed according to the requirements of EN12845.

7.3 Locations of the area of operation

7.3.1 Hydraulic demand

When identifying the design sprinklers having the greatest hydraulic demand variations in sprinkler spacing, layout, elevation, range centres, sprinkler orifice size and pipe sizes, as well as all possible locations, whether on the distribution pipes or between distribution pipes where these are connected by range pipes, shall be taken into consideration.

The correct identification of the design sprinklers in gridded installations shall be proved by displacing the area of operation by one sprinkler in each direction along the range pipes until the area with the highest pressure requirement is identified.

The correct identification of the design sprinklers in looped installations shall be proved by displacing the area of operation by one sprinkler in each direction along the distribution pipe until the area with the highest pressure requirement is identified.

7.4 Pipe layout

The pipe layout shall be branched, gridded or looped or any combination of these. For dry systems, gridded or looped pipe networks are not allowed.

7.4.1 Pipe sizing and calculation of pressure losses in pipework

Pipe sizes shall be determined using fully calculated systems, where all diameters are determined by hydraulic calculation.

7.4.2 Minimum pipe diameters

The nominal pipe diameter in any part of the sprinkler system shall not be less than DN25 for ferrous piping and not less than DN20 for copper pipe/tube or other material in accordance with appropriate specifications valid in the place of use of the systems. Pipe diameters downstream of the control valve set may decrease only in the direction of water flow.

For Type 1 buildings pipe diameters less than DN 20 but not less than DN 15 is acceptable for networked multipurpose systems if it is installed according to the manufacturer's specification. The manufacturer of the networked system shall confirm that the layout, calculation and installation of the system conform to their specifications.

7.4.3 Pipe friction loss

Calculations of pipe friction loss shall be not less than those derived from the Hazen-Williams formula:

$$p = \frac{6.05 \times 10^5}{C^{1.85} \times d^{4.87}} \times L \times Q^{1.85}$$

where:

- p is the pressure loss in the pipe, in bar;
- Q is the flow through the pipe, in litres per minute;
- d is the mean internal diameter of the pipe, in millimetres;
- C is a constant for the type and condition of the pipe (see Table 4);
- L is the equivalent length of pipe and fittings, in metres.

Pressure loss due to velocity shall be ignored. The values of C indicated in Table 4 shall be used.

Table 4 – C values for various types of pipe

Type of pipe	Value of C
cast iron	100
ductile iron	110
mild steel	120
galvanized steel	120
spun cement	130
cement lined cast iron	130
stainless steel	140
copper	140
CPVC	150
other pipe systems	According to manufacturer's specification

NOTE The list is not exhaustive

7.4.4 Static pressure difference

The static pressure difference between two inter-connecting points in a system shall be calculated from:

$$p = 0.098h$$

where:

p is the static pressure difference, in bar;

h is the vertical distance between the points, in metres.

7.4.5 Velocity

The maximum equilibrium water velocity through any valve or flow monitoring device shall be 6 m/s and at any other point in the system 10 m/s.

7.4.6 Pressure loss through fittings and valves

The pressure loss due to friction in valves, and in fittings where the direction of water flow is changed through 45° or more, shall be calculated using the formula specified in 7.4.3. The appropriate equivalent length shall be as specified by the manufacturer’s specification.

If there is a bend, tee or cross where there is a change in direction of flow and there is also a change in diameter at the same point, the equivalent pipe length and pressure loss shall be determined by using the smaller diameter.

7.4.7 Pressure loss through copper tube bends

Where the direction of water flow is changed through 45° or more, the frictional pressure loss in bends in copper tube shall be calculated as follows:

$$\text{Equivalent lengths of copper tube (C=140)} = 7.65 \times 10^{-3} Q^{0.15} d^{0.87}$$

where:

Q = water flow rate in litres per minute (l/min);

D = the tube bore in millimetres (mm).

8 Water supplies

8.1 Water supply

8.1.1 Continuity

All practical steps shall be taken to ensure the continuity and reliability of water supplies.

8.1.2 Frost protection

The pipework from the water supply to the control valve set shall be maintained at a minimum temperature of 4°C.

8.1.3 A common supply main to the building, serving both the sprinklers and domestic use, shall be permitted where the domestic water demand is added to the sprinkler system water demand. The domestic water demand shall be calculated according to the applicable national regulation. The total demand flow shall not exceed the maximum allowable flow of the piping system components.

Exception: Domestic water demand shall not be required to be added where provision is made to prevent flow on the domestic water system upon operation of sprinklers, see example in Figure 1.

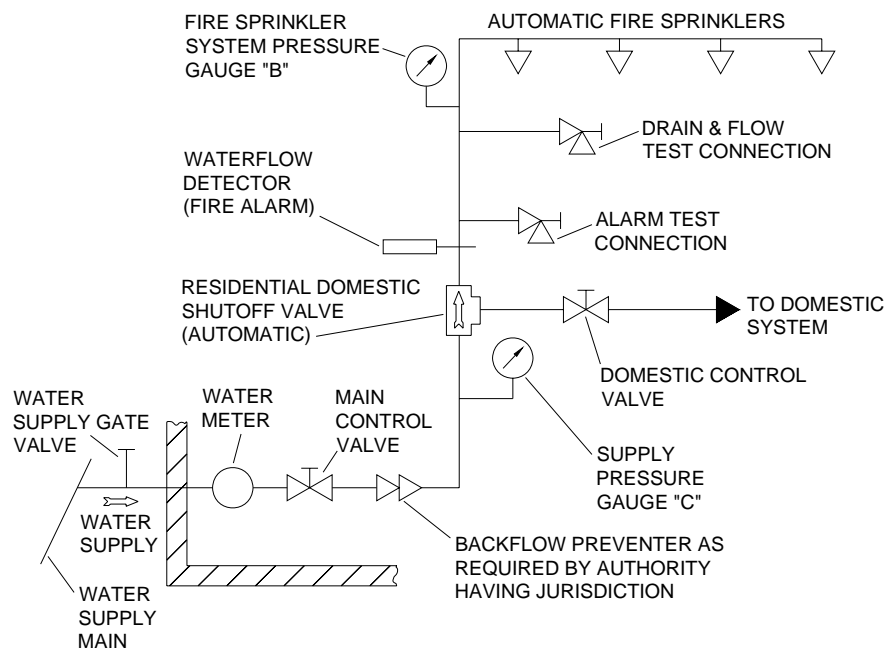

Figure 1 – Common water supply

8.2 Maximum water pressure

Except during testing, water pressure shall not exceed 12 bar in the system. The pressure in pumped systems shall take into account any increase in driver speed and pressure due to closed valve condition.

8.3 Housing of equipment for water supplies

For type 2 and type 3 buildings the water supplies, stop valves and control valve sets shall be installed such that they are safely accessible even in a fire situation. All components of the water supplies and control valve sets shall be installed such that they are secured against tampering and are adequately protected against freezing.

8.4 Test facility devices

8.4.1 The system shall be equipped with test facilities according to Table 5.

Table 5 – Type of test facilities

Type of building	Type of test facility
Type 1	Discharge test according to installers specifications
Type 2	Discharge test according to installers specifications, unless installed to compensate for other fire protection methods, then test facilities according to 8.4.2 shall be installed
Type 3	According to 8.4.2

8.4.2 Sprinkler installations shall be permanently provided with devices for measuring pressure and flow for checking compliance with clause 7 and 10 and comply with the following:

- a) All devices included in a test unit shall be suitable for its purpose and be installed in accordance with manufacturer’s specifications;
- b) The flow measuring device shall be installed at a suitable location for easy access and readings in an area maintained at a minimum temperature of 4°C upstream and close to the control valve set;
- c) All flow measuring devices shall be calibrated. The calibration shall be verified. If the device may be influenced during transportation, installation or continues use, a new calibration procedure must be verified before any test results are used to evaluate the available flow;
- d) The capacity of the flow measuring device shall be chosen so, that both the minimum as well as the maximum system demand can be read within the flow range of which it has been calibrated for. The flow measuring device shall in addition have a measuring capacity of at least 150% of the system flow demand;
- e) Pressure readings to be used for the pressure/flow test curve must only be made by a calibrated test gauge. Such a test gauge does not need to be permanently provided. However, in such case the sprinkler installation shall be equipped with a test gauge connection at or close to the control valve set;
- f) A minimum of three (3) pressure/ flow readings must be carried out to create a test curve. In addition to this, a pressure reading shall be made with no flow, i.e. the static pressure.

9 Type of water supply

9.1 General

Water supplies shall be one or more of the following:

- a) Town mains in accordance with 9.2;
- b) Storage tanks in accordance with 9.3;
- c) Pressure tanks in accordance with 9.4.

The connections between the water sources and sprinkler control valve sets shall be arranged so as to ensure that maintenance of the main components such as strainers, pumpsets, non-return valves and water meters is facilitated;

9.2 Town mains

9.2.1 General

For Type 2 and Type 3 buildings a pressure switch shall be installed and shall operate an alarm when the pressure in the supply drops to a predetermined value. The switch shall be positioned upstream of any non-return valve and shall be equipped with a test valve (see annex C).

NOTE 1 In some cases the water quality makes it necessary to fit strainers on all connections from town mains.

NOTE 2 It can be necessary to take into account extra flow required for fire brigade purposes.

NOTE 3 The agreement of the water authority will usually be needed for town main connections.

9.2.2 Boosted mains

If booster pumps are used, they shall be installed in accordance with the requirements of clause 10.

NOTE The agreement of the water authority will normally be needed for a booster pump to be connected to a town main.

Where a single pump is installed in type 2 and type 3 buildings, a by-pass connection shall be provided with at least the same dimension as the water supply connection to the pump and be fitted with a non-return valve and two stop valves. The pump or pumps shall be reserved solely for fire protection.

9.3 Storage tanks

9.3.1 General

Storage tanks shall be one or more of the following:

- pump suction tank;
- gravity tank;
- reservoir
- reduced capacity tank.

9.3.2 Water volume

The minimum effective water volume shall be calculated by multiplying the design discharge by the duration specified in Table 2 and Table 3. The water volume shall be supplied from a full capacity tank, with an effective capacity at least equal to the calculated minimum water volume.

The effective capacity of a tank shall be calculated by taking the difference between the normal water level and the lowest effective water level. If the tank is not maintained at a minimum temperature of 4°C the normal water level shall be increased by at least 1,0 m and ice venting shall be provided. Tanks shall be enclosed and easy access shall be provided.

Tanks shall be provided with an externally readable water level indicator.

9.3.3 Refill rates for full capacity tanks

Means shall be provided to refill the tank in no more than 12 h.

9.3.4 Reduced capacity tanks

The following conditions shall be met for reduced capacity tanks:

- a) the inflow shall be from a town main and shall be automatic. For Type 2 and Type 3 buildings the inflow shall be via at least two mechanical float valves. The inflow shall not adversely influence the pump suction;
- b) the tank capacity plus the inflow shall be sufficient to supply the system at full capacity as specified in 9.3.2;
- c) it shall be possible to check the capacity of the inflow;
- d) the inflow arrangement shall be accessible for inspection.

9.3.5 Refill rates for reduced capacity tanks

Means shall be provided to refill the tank in no more than 12 h.

9.4 Pressure tanks

Pressure tanks shall be designed, installed and maintained in accordance with EN 12845.

10 Pumps

10.1 General for all building types

The pump shall have a stable H(Q) curve, i.e. one in which the maximum head and shut-off head are coincidental, and the total head declines continuously with increasing rate of flow (see EN 12723).

Pumps shall be driven either by electric motors or diesel engines, capable of providing at least the power required to comply with the following:

- a) for pumps with non-overloading power characteristic curves, the maximum power required at the peak of the power curve;
- b) for pumps with rising power characteristic curves, the maximum power for any conditions of pump load, from zero flow to a flow corresponding to a pump NPSH required equal to 16m or maximum suction static head plus 11m, whichever is greater.

The coupling between the driver and the pump of horizontal pumpsets shall be of a type which ensures that either can be removed independently and in such a way that pump internals can be inspected or replaced without

affecting suction or discharge piping. End suction pumps shall be of the "back pull-out" type. Pipes shall be supported independently of the pump.

Pump compartments for diesel engine driven pumps shall be provided with adequate ventilation in accordance with the supplier's recommendations.

10.2 Compartments for pumpsets, type 2 buildings

10.2.1 General

Pumpsets shall be housed in a compartment having a fire resistance of no less than 30 min.

10.2.2 Sprinkler protection

The pumpset shall be installed in a sprinkler protected area.

10.3 Compartments for pumpsets, type 3 buildings

10.3.1 General

Pumpsets shall be housed in a compartment having a fire resistance of no less than 60 min, used for no other purpose than fire protection. It shall be one of the following (in order of preference):

- a) a separate building;
- b) a building adjacent to a sprinkler protected building with direct access from outside;
- c) a compartment within a sprinkler protected building with direct access from outside.

10.3.2 Sprinkler protection

The pumpset shall be installed in a sprinkler protected area.

10.4 Temperature requirements, all building types

10.4.1 The pump compartment shall be maintained at or above the following temperature:

- +4 °C for electric motor driven pumps;
- +10 °C for diesel engine driven pumps.

10.4.2 The water supply temperature shall not exceed 40°C. Where submersible pumps are utilized, the water temperature shall not exceed 25°C, unless the suitability of the motor has been proven for temperatures up to 40 °C, in accordance with prEN 12259-12.

10.5 Valves and accessories, all building types

A stop valve shall be fitted in the pump suction pipe and a non-return and a stop valve shall be fitted in the delivery pipe.

Any taper pipe fitted to the pump outlet shall expand in the direction of flow at an angle not exceeding 15°. Valves on the delivery side shall be fitted after any taper pipe.

Means for venting all cavities of the pump casing shall be provided unless the pump is made self-venting by arrangement of its branches.

Diesel engine cooling circuits usually use the same water. However, if additional water is used, it shall also be taken into account.

Arrangements for continuous flow shall be made to prevent overheating of the pump.

Tappings on the pumps for inlet and outlet pressure gauges shall be easily accessible.

10.6 Suction conditions, all building types

10.6.1 General

Wherever possible, horizontal centrifugal pumps shall be used, installed with a positive suction head. i.e. in accordance with the following:

- at least two thirds of the effective capacity of the suction tank shall be above the level of the pump centre line;
- the pump centre line shall be no more than 2 m above the low water level of the suction tank.

If this is not feasible, the pump may be installed under suction lift conditions or vertical turbine pumps may be used.

NOTE Suction lift and submersible pump arrangements should be avoided and only used when it is not practicable to arrange positive suction head.

10.6.2 Suction pipe, all building types

10.6.2.1 General

The pump suction shall be connected to a straight or taper pipe at least two diameters long. The taper pipe shall have a horizontal top side.

Suction piping shall be laid either horizontal or with a continuous slight rise towards the pump to avoid the possibility of air locks forming in the pipe.

A foot valve shall be fitted where the centre line of the pump is above the low water level.

10.6.2.2 Positive head

The diameter shall be such that a velocity of 1,8 m/s is not exceeded when the pump is operating at maximum demand flow.

10.6.2.3 Suction lift

The diameter shall be such that a velocity of 1,5 m/s is not exceeded when the pump is operating at maximum demand flow.

The height from the low water level to the centre line of the pump shall not exceed 3,2 m.

The suction pipe shall be positioned in the tank or reservoir in accordance with EN 12845, as appropriate, or fitted with an anti vortex inhibitor. A foot valve shall be fitted at the lowest point on the suction pipe. Each pump shall have automatic priming arrangements in accordance with 10.6.2.4.

10.6.2.4 Pump priming, all building types

Each pump shall be fitted with a priming arrangement.

10.6.2.4.1 Exception for type 1 and 2 buildings

The pump can be of the self priming type.

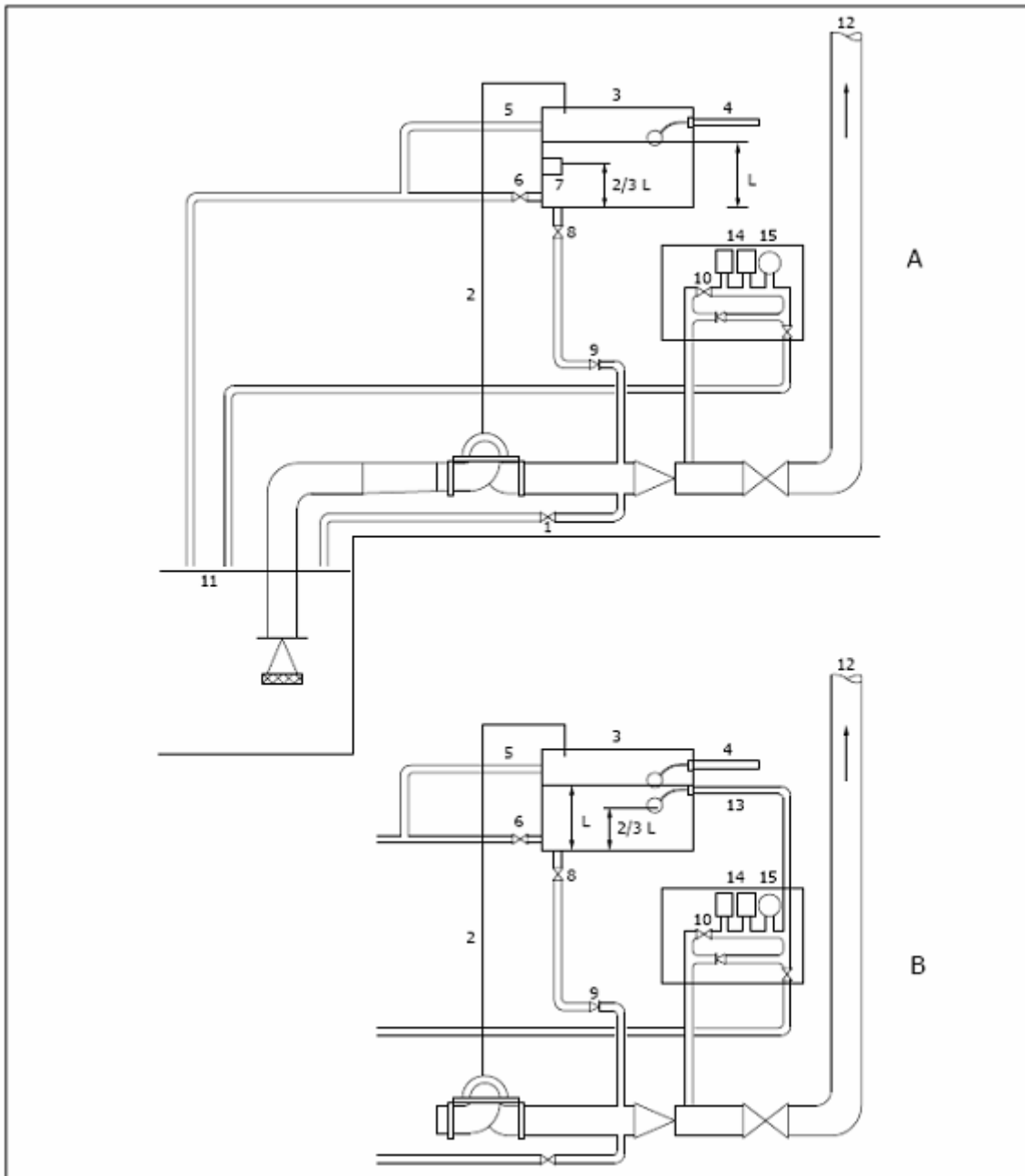

Key

- | | |
|--------------------------------------|--|
| 1 Test drain and valve | 9 Priming supply non-return valve |
| 2 Pump air bleed and min flow line | 10 Pump start arrangement |
| 3 Pump priming tank | 11 Suction tank |
| 4 Inflow | 12 Installation trunk main |
| 5 Over flow | 13 Low level valve for pump starting |
| 6 Drain valve | 14 Pressure switches for pump starting |
| 7 Low level switch for pump starting | 15 Pressure gauge |
| 8 Priming supply stop valve | |

Figure 2 — Pump priming arrangement for suction lift

The size of the priming tank and the pipe shall be in accordance with pump manufacturer's instruction.

10.7 Performance characteristics, all building types

10.7.1 General

The rated duty of the pump shall be a function of the most unfavourable area curve. When measured by the supplier's test facility, the pump shall provide a pressure at least 0,5 bar higher than that required for the most unfavourable area. The pump shall also be capable of providing the flow and pressure of the most favourable area at all water supply water levels (see Figure 3).

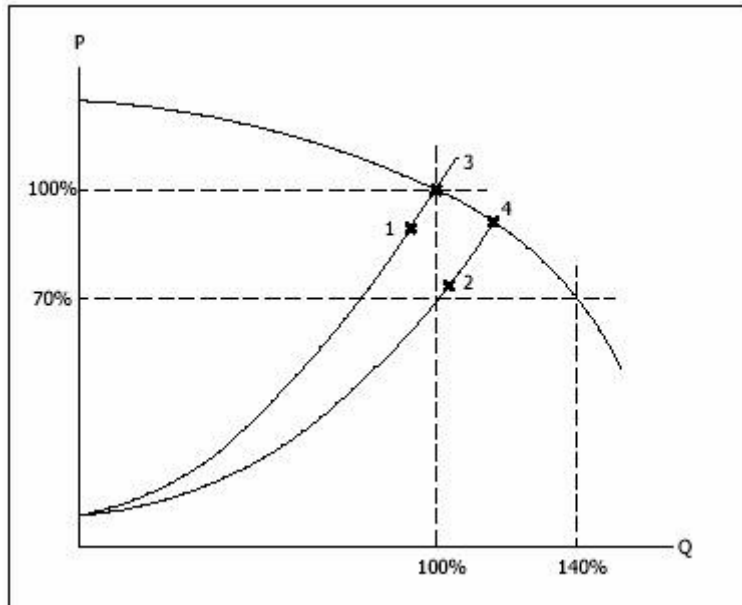

- Key**
 1 Most unfavourable area
 2 Design pump flow
 3 Maximum demand flow
 4 Most favourable area
 x Flow
 y Pressure

Figure 3 — Typical pump curve

10.7.2 Pressure and water capacity of town mains

A test shall be carried out to show that the unboosted supply provides a flow rate equal to the maximum demand flow plus 20 %, at a pressure of at least 0,5 bar, as measured at the pump inlet. This test shall be carried out at a time of maximum demand on the main.

10.7.3 Start device

10.7.3.1 Number of pressure switches

For type 1 building at least one pressure switch shall be provided to start the pumpset. For type 2 and 3 buildings at least two pressure switches shall be provided to start the pumpset. The switch(es) shall start the pump with normally closed contacts.

10.7.3.2 Pump start and stop

The pumpset shall start automatically when the pressure in the trunk main falls to a value of no less than $0,8P$, where P is the pressure at the closed valve condition. Once the pump has started it shall continue to run until it is manually stopped.

10.7.3.3 Testing the pressure switch(es), type 1 and 2 buildings

A means shall be provided to test all pressure switches used to start the pump.

10.7.3.4 Testing the pressure switches, type 3 buildings

A means shall be provided to test all pressure switches used to start the pump. If any isolating valve is installed on the connection between the trunk main and any pump starting pressure switch, a non-return valve shall be installed in parallel with the isolating valve so that a fall in pressure on the trunk main will be transmitted to the pressure switch even when the isolating valve is closed.

10.8 Electrically driven pumpset, all building types

10.8.1 General

The electric supply system shall be available at all times.

10.8.2 Electrical supply

10.8.2.1 The supply to the pump controller shall be solely for use of the sprinkler pumpset and separate from all other connections. Where permitted by the electrical utility, the electrical supply to the pump controller shall be taken from the input side of the main switch on the incoming supply to the premises and where this is not permitted, by a connection from the main switch.

The fuses in the pump controller shall be of high rupturing capacity, capable of carrying the start current for a period of no less than 20 s.

10.8.2.2 When cables are running through non sprinkler protected areas the cables shall be in accordance with IEC 60331.

Cables shall be in single lengths.

10.8.3 Main switchboard, type 3 buildings only

The main switchboard for the premises shall be situated in a fire compartment used for no other purpose than for electrical power supplies.

The electrical connections in the main switchboard shall be such that the supply to the pump controller is not isolated when isolating other services.

10.8.4 Installation between the main switchboard and the pump controller, type 3 buildings only

The current for calculating the correct dimension for the cable shall be determined by taking 150 % of the largest possible full load current.

10.8.5 Pump controller, all building types

10.8.5.1 The pump controller shall be able:

- a) to start the motor automatically on receiving a signal from the start device;
- b) to start the motor on manual actuation;
- c) to stop the motor by manual actuation.

In the case of submersible pumps a plate with its characteristics shall be affixed to the pump controller.

10.8.5.2 Except in the case of submersible pumps, the pump controller shall be situated in the same compartment as the electric motor and pump.

10.8.5.3 Contacts shall comply with utilization category AC-4 of EN 60947-1 and EN 60947-4.

10.8.6 Monitoring of pump operation, type 3 buildings only

10.8.6.1 The following conditions shall be monitored (see annex B):

- power available to the motor and, where AC, on all phases;
- pump on demand;
- pump running;
- start failure.

10.8.6.2 All monitored conditions shall be visually indicated individually in the pump room. They shall also be visually indicated at a location permanently attended by responsible personnel. Pump running and fault alarms shall also be audibly indicated at the same place.

10.8.6.3 The visual fault indication shall be yellow. The audible signals shall have a signal strength of at least 75 dB and shall be able to be silenced.

10.8.6.4 A lamp test for checking the signal lamps shall be provided.

10.9 Diesel engine driven pumpset, all type of buildings

10.9.1 General

The diesel engine shall be capable of operating continuously at full load at site elevation with a rated continuous power output in accordance with ISO 3046.

The pump shall be fully operational within 15 s of the beginning of any starting sequence.

Horizontal pumps shall have a direct drive.

The automatic start and operation of the pumpset shall not depend on any energy sources other than the engine and its batteries.

10.9.2 Engines

The engine shall be capable of starting at an engine room temperature of 5 °C.

It shall be provided with a governor to control the engine speed to $\pm 5\%$ of its rated speed under normal load conditions, and be constructed so that any mechanical device fitted to the engine which could prevent the engine starting automatically, will return to the starting position.

10.9.3 Cooling system

The cooling systems shall be one of the following types:

- a) Cooling by water from the sprinkler pump directly into the engine-cylinder jackets, via a pressure reducing device if necessary, in accordance with the supplier's specification. The outlet pipe shall be open so that the discharge water is visible or equipped with a water flow detector;
- b) A heat exchanger, where the water is taken from the sprinkler pump, via a pressure reducing device if necessary, in accordance with the supplier's specification. The outlet pipe shall be open so that the discharge

water is visible or equipped with a water flow detector. An auxiliary pump driven by the engine shall circulate the water in the closed circuit. If the auxiliary pump is belt driven, there shall be multiple belts such that even if up to half the belts are broken, the remaining belt(s) are able to drive the pump. The capacity of the closed circuit shall conform to the value specified by the engine supplier;

- c) An air cooled radiator with a fan multiple belt driven from the engine. If half the belts should break, the remaining belts shall be capable of driving the fan. An auxiliary pump driven by the engine shall circulate the water in the closed circuit. If the auxiliary pump is belt driven, there shall be multiple belts such that even if half the belts are broken, the remaining belts are able to drive the pump. The capacity of the closed circuit shall conform to the value specified by the engine supplier;
- d) Direct air cooling of the engine by means of a multiple belt driven fan. When half the belts are broken the remaining belts shall be capable of driving the fan.

10.9.4 Air filtration

The engine air intake shall be fitted with a suitable filter.

10.9.5 Exhaust system

The exhaust pipe shall be fitted with a suitable silencer and the total back pressure shall not exceed the supplier's recommendation.

Where the exhaust pipe is higher than the engine, means shall be provided to prevent any condensate flowing back to the engine. The exhaust pipe shall be positioned in such a way as to prevent exhaust gases from re-entering the pump room. It shall be insulated and installed so that it does not cause a fire ignition risk.

10.9.6 Fuel, fuel tank and fuel feed pipes

The quality of the diesel fuel used shall conform to the supplier's recommendations. The fuel tank shall contain sufficient fuel to enable the engine to run on full load for 3 hours.

The fuel tank shall be of welded steel.

The fuel tank shall be fixed at a higher level than the motor's fuel pump to ensure a positive head, but not directly above the engine. The fuel tank shall have a sturdy fuel level gauge.

Any valves in the fuel feed pipe between the fuel tank and the engines shall be placed adjacent to the tank, have an indicator and be locked in the open position. Pipe joints shall not be soldered. Metallic pipes shall be used for fuel lines.

The feed pipe shall be situated at least 20 mm above the bottom of the fuel tank. A drain valve of at least 20 mm diameter shall be fitted to the base of the tank.

10.9.7 Starting mechanism

10.9.7.1 General

Automatic and manual starting systems shall be provided and shall be independent except that the starter motor and batteries may be common to the two systems.

It shall be possible to start the diesel engine both automatically, upon receipt of a signal from the start device, and manually by means of a push button on the pump controller. It shall be possible to shut down the diesel engine only manually; engine monitoring devices shall not cause the engine to stop.

The rated voltage of the batteries and starter motor shall be no less than 12 V.

10.9.7.2 Automatic starting system

The automatic starting sequence shall make three attempts to start the engine, each one of 5 s to 10 s duration, with a maximum pause of 10 s between each attempt. The starting device shall reset itself automatically. It shall function independently of the line power supply.

The system shall switch over automatically to the other battery after each starting attempt. The control voltage shall be drawn from both batteries simultaneously. Facilities shall be provided to prevent one battery having an adverse effect on the other.

10.9.7.3 Emergency manual starting system

Emergency manual start facilities, with starting power available from both batteries, shall be provided.

10.9.7.4 Test facility for manual starting system

A manual start test button and indicator lamp shall be provided to permit periodic testing of the manual electric start system.

The manual start test button shall only be brought on line after an automatic engine start followed by a shut down or after three repeated unsuccessful attempts to start automatically. Either of the two conditions shall cause the indicator lamp to light and bring the manual start test button on line in parallel with the emergency manual start push button.

When a manual start test has been carried out, the circuit used for this purpose shall automatically become inoperable and the indicator lamp shall be extinguished. The automatic start facility shall be available, even when the manual start test button circuit is activated.

10.9.7.5 Starter motor

The electric starter motor shall incorporate a moveable pinion, which engages automatically with the flywheel gear rim. To avoid shock loading, the system shall not apply full power to the starting motor until the pinion is fully engaged. The pinion shall not be ejected from engagement by spasmodic engine firing. There shall be a means to prevent attempted engagement when the engine is rotating.

The starter motor shall cease to operate and shall return to the rest position if the pinion fails to engage with the flywheel gear ring. After the first failure to engage, the starter motor shall automatically make up to five further attempts to achieve engagement.

10.9.8 Electric starter motor batteries

Two separate battery power supplies shall be provided and shall be used for no other purpose. Batteries shall be either open nickel-cadmium prismatic rechargeable cells complying with EN 60623 or lead-acid positive batteries complying with EN 50342.

The electrolyte for lead acid batteries shall comply with EN 50342.

Batteries shall be selected, used, charged and maintained in accordance with the requirements of this standard and with the supplier's instructions.

A hydrometer, suitable for checking the density of the electrolyte, shall be provided.

10.9.9 Battery chargers

Each starter battery shall be provided with an independent, continuously connected, fully automatic, constant potential charger, as specified by the supplier. It shall be possible to remove either charger while leaving the other operational.

NOTE 1 Chargers for lead acid batteries should provide a float voltage of $(2,25 \pm 0,05)$ V per cell. The nominal charging voltage should be suitable for local conditions (climate, regular maintenance, etc.). A boost charge facility should be provided for charging to a higher voltage not exceeding 2,7 V per cell. The charger output should be between 3,5% and 7,5% of the 10 h capacity of the battery.

NOTE 2 Chargers for open nickel-cadmium prismatic batteries should provide a float voltage of $(1,445 \pm 0,025)$ V per cell. The nominal charging voltage should be suitable for local conditions (climate, regular maintenance, etc.). A boost charge facility should be provided for charging to a higher voltage not exceeding 1,75 V per cell. The charger output should be between 25% and 167% of the 5 h capacity of the battery.

10.9.10 Siting of batteries and chargers

Batteries shall be mounted on stands.

The chargers may be mounted with the batteries. Batteries and chargers shall be located in readily accessible positions where the likelihood of contamination by oil fuel, damp, pumpset cooling water, or of damage by vibration is minimal. The battery shall be as close as possible to the engine starter motor, subject to the above constraints, in order to minimize voltage drop between the battery and starter motor terminal.

10.9.11 Starter alarm indication

The following conditions shall each be indicated both to a local manned center and an alarm receiving center:

- a) the use of any switch which prevents the engine starting automatically;
- b) the failure of the engine to start after the three attempts;
- c) pump running;
- d) diesel controller fault;

The warning lights shall be appropriately marked.

10.9.12 Tools and spare parts

A standard kit of tools as recommended by the engine and pump manufacturers shall be provided.

10.9.13 Engine tests and exercising

10.9.13.1 Manufacturer's test and certification of results

Each complete engine and pumpset shall be tested by the pump manufacturer for no less than 1,5 h at the rated flow. The following shall be recorded on the test certificate:

- a) the engine speed with the pump churning;
- b) the engine speed with the pump delivering water at the rated flow;
- c) the pump churning pressure;
- d) the suction head at the pump inlet;
- e) the pump outlet pressure at the rated flow downstream of any outlet orifice plate;
- f) the ambient temperature;

- g) the cooling water temperature rise at the end of the 1,5 h run;
- h) the cooling water flow rate;
- i) the lubrication oil temperature rise at the end of the test run;
- j) where the engine is fitted with a heat exchanger the initial temperature and the temperature rise of the engine closed circuit cooling water.

10.9.13.2 Site commissioning test

When commissioning an installation the automatic starting system of the diesel engine shall be activated with the fuel supply isolated for the three cycles each of no less than 15 s cranking and no more than 15 s or less than 10 s rest. After completion of the three starting cycles the fail to start alarm shall operate. The fuel supply shall then be restored and the engine shall start when the manual start test button is operated.

11 Installation type and size

11.1 Wet pipe installations

11.1.1 General

Except where covered by 11.1.2, wet pipe installations are permanently charged with water under pressure. Wet pipe installations shall be installed only in premises where there is no possibility of frost damage to the installation.

Only wet pipe installations shall be used for grid and loop systems.

11.1.2 Protection against freezing

Parts of the installation subject to freezing may be protected in accordance with EN 12845. For pipe systems not covered by this standard the manufacturer’s specification shall be used.

NOTE Special consideration should be given to the compatibility of materials used in conjunction with any plastic piping system.

11.1.3 Size of installations

The maximum area controlled by a single control valve set, including any sprinklers in a subsidiary extension, shall not exceed 500 sprinklers and comply with the requirements in Table 6.

Table 6 — Maximum protected area in wet pipe installations

Type of building	Maximum protected area per control valve set
Type 1	1 dwelling unit
Type 2 and 3	1 dwelling unit, except for dwelling units that are considered to be occupied on a temporary basis such as hotels, motels, hospitals, student housing etc, this also includes care homes

See also Annex A for alarm zoning requirements

11.2 Dry pipe installations

11.2.1 General

Dry pipe installations are normally charged with air or inert gas under pressure downstream of the control valve set and water under pressure upstream of the control valve set.

A permanent air/inert gas supply to maintain the pressure in the pipework shall be installed. The installation shall be pressurized to fall within the pressure range recommended by the control valve manufacturer.

Residential sprinklers used in dry pipe installations shall be specifically investigated for its suitability and shall be installed in accordance with the manufacturer's installation specification.

11.2.2 Size of installations

The net volume of the pipework downstream of the control valve set shall be calculated and tested so that the maximum time between the hydraulically most remote sprinkler opening and water discharging is less than 15 s. The test shall be carried out using the remote test valve.

11.3 Pre-action installations

11.3.1 General

Residential sprinklers used in pre-action installations shall be specifically investigated for suitability and shall be installed in accordance with the manufacturer's specifications.

11.3.2 Automatic detection system

The detection system shall be installed in all rooms and compartments protected by the pre-action sprinkler system and shall comply with the relevant parts of EN 54 or with appropriate specifications valid in the place of use of the sprinkler system.

11.3.3 Size of installations

The net volume of the pipework downstream of the control valve set shall be calculated and tested so that the maximum time between the hydraulically most remote sprinkler opening and water discharging is less than 15 s. The test shall be carried out using the remote test valve.

12 Spacing and location of sprinklers

12.1 General

Unless specifically investigated and contained in the manufacturer's specifications, sprinklers shall be installed according to the requirements of this guideline. When specifically tested and the test results demonstrate that deviations from clearance requirements to structural members, clearance between sprinklers, ceilings slopes exceeding the maximums in this guideline, etc, do not impair the sensitivity or performance of the sprinklers or their ability to control or suppress a fire, their positioning and location in accordance with the test results shall be permitted.

Sprinklers shall be located so as not to exceed the maximum protection area per sprinkler according to the manufacturer's specifications.

Sprinklers shall be positioned and located so as to provide satisfactory performance with respect to activation time and distribution.

Residential sprinklers shall be installed in rooms having ceiling slopes not exceeding 9.5° or 16.7% unless specifically tested and found appropriate for other types of ceiling construction and contained in the manufacturer's specifications.

Quick Response Extended Coverage sprinklers shall be installed in rooms having ceiling slopes not exceeding 9.5° or 16.7%.

Upright sprinklers shall be fitted with yoke arms parallel to the pipe.

Except when dry sprinklers are used, sprinklers on dry pipe systems shall be upright.

Only quick response spray sprinklers shall be installed above open suspended ceilings in accordance with EN 12845. Residential sprinklers shall not be installed above open suspended ceilings unless specifically investigated and contained in the manufacturer's specification.

A clear space of 0,5 meters shall be maintained below the deflector of Quick Response Pendent, Upright, Conventional and Dry sprinklers.

Unless otherwise specified the spacing and location of Quick Response Pendent, Upright, and Conventional and Dry sprinklers, shall be in accordance with EN 12845.

12.2 Wardrobes

Sprinklers as defined in 14.2 and used in wardrobes shall be permitted to be installed within 300 mm of the ceiling in order to avoid obstructions near the ceiling.

In all wardrobes, including those wardrobes housing mechanical equipment, that are not larger than 11 m³ in size, a single sprinkler at the highest ceiling space in the wardrobe shall be sufficient without regard to obstructions.

12.3 Spacing of Residential and Quick Response Extended Coverage sprinkler

12.3.1 Maximum area of coverage

The maximum area of coverage per sprinkler shall be determined in accordance with the manufacturer's specifications. In no case can the maximum area of coverage per sprinkler exceed 37 m².

12.3.2 Maximum distance between sprinklers

For Residential and Quick Response Extended Coverage sprinklers, the maximum distance between sprinklers shall be based on the centreline distance between sprinklers on the branchline or on adjacent branchlines and shall be measured along the slope of the ceiling. The maximum distance between sprinklers shall not be more than the greatest dimension of the design area of coverage for which the Residential or Quick Response Extended Coverage sprinkler is being used as shown in the manufacturer's specifications.

12.3.3 Minimum distance between sprinklers

Regardless of the amount of ceiling slope, sprinklers shall not be installed at intervals of less than 2,4 m as measured in the horizontal plane except in the following cases:

- where a manufacturer publishes a value greater than 2.4 m, the value referenced in the manufacturer's specifications shall be used
- where arrangements are made to prevent adjacent sprinklers from wetting each other. This may be achieved by using baffles:
 - having minimum dimensions of 200 mm x 150 mm such that bottoms of the baffles extend to a level at least even with the deflectors of pendent sprinklers or the tops of the baffles extend at least 2,5 cm above the deflectors of upright sprinklers
 - located midway between sprinklers
 - constructed of non-combustible or limited combustible material that stays in place during sprinkler operation

- or by using intervening constructional features that provide the same function;
- No sprinklers shall be located within the design area of coverage for which a Quick Response Extended Coverage sprinkler is being used.

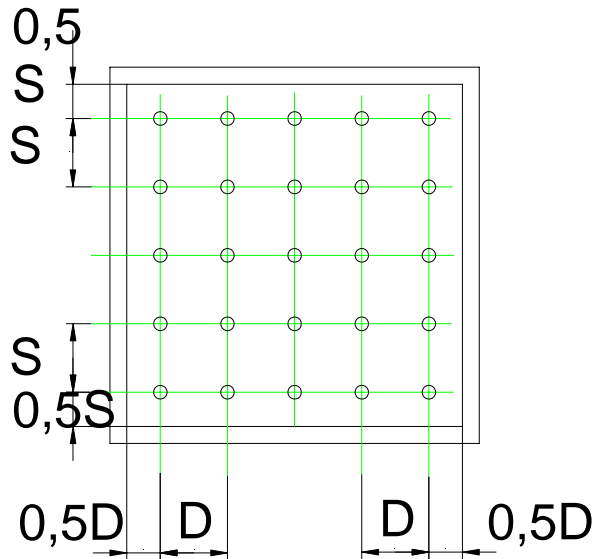

Key

S Distance between sprinklers on branch lines

D Distance between branch lines

Figure 4 — Ceiling sprinkler spacing

12.4 Location of Residential and Quick Response Extended Coverage sprinklers in relation to walls and ceilings

12.4.1 The maximum distance from walls shall not be more than one-half the spacing of the design area of coverage for which the sprinkler is being used, see Figure 4.

12.4.2 The minimum distance from any wall shall be 100 mm for upright, pendent and conventional sprinklers. The minimum distance from any wall to a sidewall sprinkler except the wall upon which it is mounted shall not be less than 100mm.

12.5 Deflector position of Residential and Quick Response Extended Coverage sprinkler

Unless indicated otherwise in the manufacturer’s specification, Residential pendent or Residential upright sprinklers shall be positioned with their deflectors between 25 mm and 100 mm below the ceiling.

Quick Response Extended Coverage Upright & Pendent Sprinklers shall be positioned with their deflectors between 25 mm and 300 mm below the ceiling.

Residential Sidewall Sprinklers and Extended Coverage Sidewall Sprinklers shall be positioned with their deflectors 100 – 150 mm below the ceiling and their deflectors shall not be located more than 150 mm from the wall upon which they are mounted and shall be positioned such that the leading edge of the deflector is oriented parallel with the ceiling.

Where a manufacturer’s specifications permit other deflector positioning, those specifications shall be permitted

12.6 Obstructions in relation to Residential and Quick Response Extended Coverage sprinklers

12.6.1 Pendent and upright sprinklers.

Pendent and upright sprinklers shall be positioned at least 900 mm away from obstructions such as ceiling fan housings, light fixtures, etc. unless otherwise specified in chapter 12.6.1, the distance being measured from the center of the sprinkler to the nearest surface of the obstruction.

Pendent and upright sprinklers shall be positioned with respect to continuous obstructions below the sprinkler like beams in accordance with Figure 6 and Table 7.

Pendent and upright sprinklers shall be positioned with respect to an obstruction against a wall such as a soffit in accordance with Figure 5.

Pendent and upright sprinklers may be located closer to an obstruction provided an additional sprinkler is located on the other side of the obstruction and the distance from the center of the sprinkler to the nearest surface of the obstruction is not less than 100 mm.

Where the area of ceiling fan blades is larger than 50 percent of the total area in which they rotate, the pendent and upright sprinkler shall be installed according to Figure 6 and Table 7 or an additional sprinkler shall be located on the other side of the ceiling fan.

NOTE Most commercially available ceiling fans have blades that are less than 50 percent of the total area in which they rotate and therefore, other than their housings, do not qualify as an obstruction.

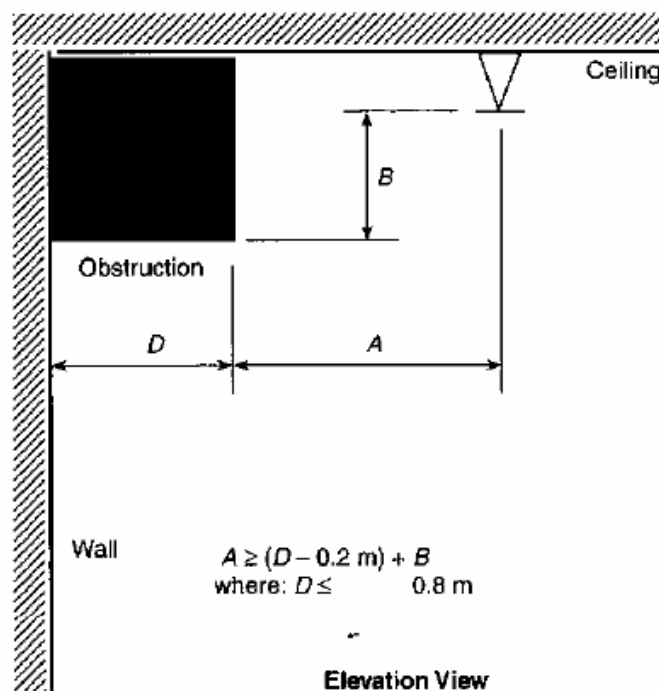

Figure 5 – Pendent sprinkler distances from obstruction

Reprinted with permission from NFPA 13D, Installation of Sprinkler Systems in One and Two Family Dwellings and Manufactured Homes, copyright © 2006 National Fire Protection Association

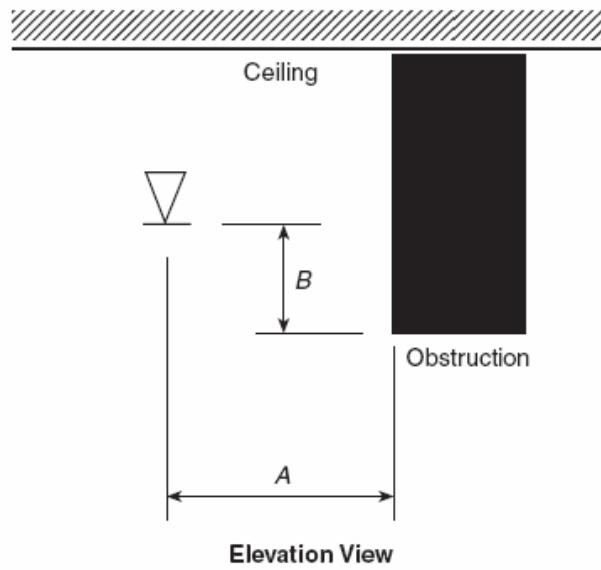

Figure 6 – Pendent sprinkler distances from obstruction

Reprinted with permission from NFPA 13D, Installation of Sprinkler Systems in One and Two Family Dwellings and Manufactured Homes, copyright © 2006 National Fire Protection Association

Table 7 – Pendent sprinkler distances from obstruction

Distance from Sprinklers to Side of Obstruction (A) (a?)	Maximum Allowable Distance of Deflector Above Bottom of Obstruction (B) (b?)
Less than 300mm	0
300mm to less than 450mm	0
450mm to less than 600mm	25mm
600 to less than 750mm	25mm
750mm to less than 900mm	25mm
900mm to less than 1050mm	75mm
1050mm to less than 1200mm	75mm
1200mm to less than 1350mm	125mm
1350mm to less than 1500mm	175mm
1500mm to less than 1650mm	175mm
1650mm to less than 1800mm	175mm
1800mm to less than 1950mm	225mm
1950mm to less than 2100mm	275mm
2100 and greater	350mm

Reprinted with permission from NFPA 13D, Installation of Sprinkler Systems in One and Two Family Dwellings and Manufactured Homes, copyright © 2006 National Fire Protection Association

12.6.2 Sidewall Sprinklers

- Sidewall sprinklers shall be positioned at least 1500 mm away from obstructions such as ceiling fan housings, light fixtures, etc. unless otherwise specified in chapter 12.6.2., the distance being measured from the center of the sprinkler to the nearest surface of the obstruction.
- Where the area of ceiling fan blades is larger than 50 percent of the total area in which they rotate, the sidewall sprinkler shall be installed according to Figures 7 and 8 and Tables 8 and 9 or an additional sprinkler shall be located on the other side of the ceiling fan.

NOTE Most commercially available ceiling fans have blades that are less than 50 percent of the total area in which they rotate and therefore, other than their housings, do not qualify as an obstruction.

- Sidewall sprinklers shall be positioned with respect to continuous obstructions like beams and soffits in accordance with Figures 7 and 8 and Tables 8 and 9. See also 12.6.1.
- Sprinklers may be located closer to an obstruction when an additional sprinkler is located on the other side of the obstruction and the distance from the center of the sprinkler to the nearest surface of the obstruction is not less than 100 mm.
- Unless otherwise specified (see 12.6.1), soffits used for the installation of sidewall sprinklers where the sidewall sprinkler is mounted on the vertical face of the soffit shall not horizontally project more than 200 mm from the wall. Where soffits horizontally project more than 200 mm from the wall, sprinklers shall be installed under the soffits.

Table 8 – Sidewall sprinkler distances and maximum depth of an obstruction located perpendicular to the direction of throw

Distance from Sidewall Sprinkler to Side of Obstruction (A)	Maximum Allowable Distance of Deflector Above Bottom of Obstruction (B)
Less than 2.4m	Not Allowed
2.4m to less than 3m	25mm
3m to less than 3.3m	50mm
3.3m to less than 3.6m	75mm
3.6m to less than 3.9m	100mm
3.9m to less than 4.2m	150mm
4.2m to less than 4.5m	175mm
4.5m to less than 4.8m	225mm
4.8 to less than 5.1	275mm
5.1 or greater	350mm

Reprinted with permission from NFPA 13D, Installation of Sprinkler Systems in One and Two Family Dwellings and Manufactured Homes, copyright © 2006 National Fire Protection Association

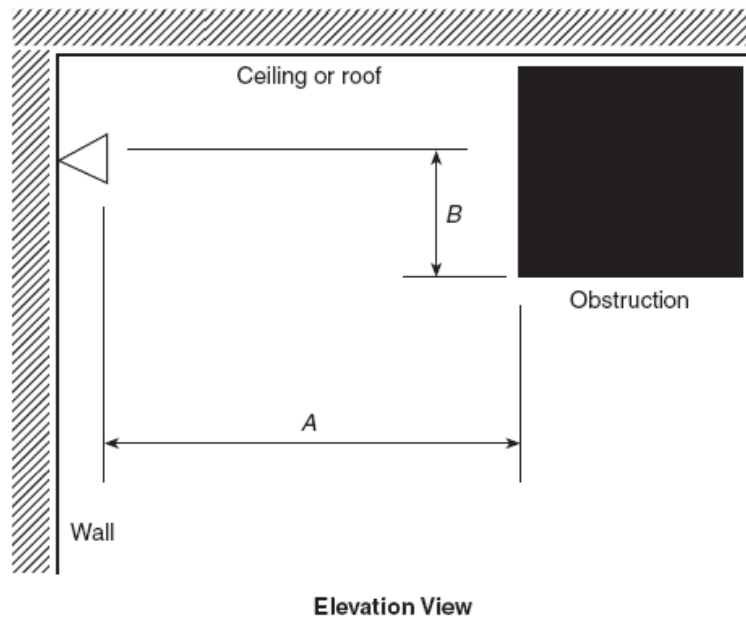

Figure 7 – Position of sidewall sprinklers to avoid obstacles to discharge

Reprinted with permission from NFPA 13D, Installation of Sprinkler Systems in One and Two Family Dwellings and Manufactured Homes, copyright © 2006 National Fire Protection Association

Table 9 – Position of sidewall sprinklers to avoid obstacles to discharge

Distance from Sidewall Sprinkler to Side of Obstruction (A)	Maximum Allowable Distance of Deflector Above Bottom of Obstruction (B)
Less than 450mm	0
450mm to less than 900mm	25mm
900mm to less than 1200mm	75mm
1200mm to less than 1350mm	125mm
1350mm to less than 1800mm	175mm
1800mm to less than 1950mm	225mm
1950mm to less than 2100mm	275mm
2100mm to less than 2250mm	350mm

Reprinted with permission from NFPA 13D, Installation of Sprinkler Systems in One and Two Family Dwellings and Manufactured Homes, copyright © 2006 National Fire Protection Association

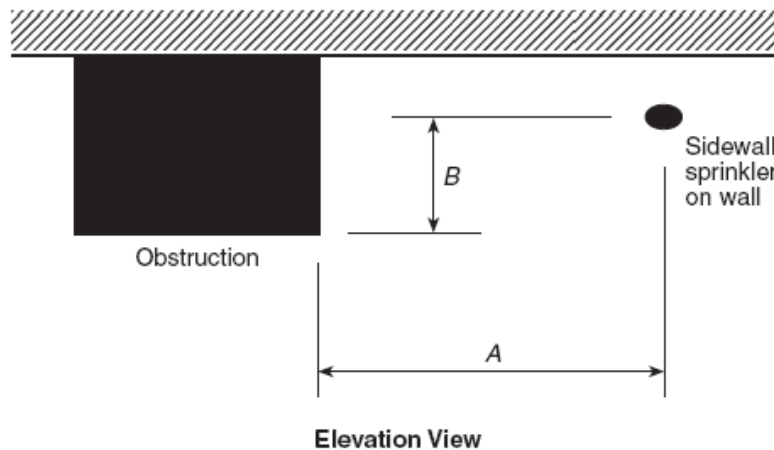

Figure 8 – Position of sidewall sprinklers to avoid obstacles to discharge

Reprinted with permission from NFPA 13D, Installation of Sprinkler Systems in One and Two Family Dwellings and Manufactured Homes, copyright © 2006 National Fire Protection Association

12.6.3 Sidewall Sprinkler installed above Cabinets

Soffits used for the installation of sidewall sprinklers above cabinets such as kitchen cabinets may project horizontally up to 300 mm from the wall without requiring the installation of sprinklers either underneath the soffit nor underneath the cabinet.

Where sidewall sprinklers are more than 900 mm above the top of cabinets and the cabinets project no more than 300 mm from the wall, then the sidewall sprinkler may be installed directly on the wall in accordance with 12.6.2.

13 Pipe sizing and layout

Requirements for pipe sizing and layout are described in chapter 7.

14 Sprinkler design characteristics and uses

14.1 General

Only new (i.e. unused) sprinklers shall be used. Sprinklers shall not be painted unless applied by the manufacturer.

14.2 Sprinkler types and application

Unless otherwise indicated, sprinklers used in residential occupancies shall be of a Residential, Quick Response Extended Coverage, Quick Response Spray or Quick Response Conventional type.

Standard response spray sprinklers are allowed inside saunas according to EN 12845.

Sprinklers shall not be used on systems other than wet pipe systems unless specifically tested for use on that particular type of system and accepted by the authority.

Standard coverage dry sprinklers shall be permitted to be installed in unheated areas according to EN 12845.

14.3 Sprinkler nominal operating temperatures

For specification of nominal operating temperatures, see EN 12259-1.

Sprinklers with an ordinary temperature rating shall be installed where maximum ambient ceiling temperatures do not exceed 38°C. Sprinklers with an intermediate temperature rating shall be installed where maximum ambient ceiling temperatures are between 39°C and 66°C.

Sprinklers installed in areas such as saunas where the ambient ceiling temperature exceeds 66°C shall have a temperature rating close to but not lower than 30°C above the highest anticipated ambient temperature.

Sprinklers under clear glass or clear plastic skylights or roofs exposed to direct rays of sunlight shall have an operating temperature of not less than 93°C.

Sprinklers having an intermediate temperature rating shall be installed in unventilated concealed spaces under an uninsulated roof or in an unventilated attic.

Special consideration shall be given to the temperature rating of sprinklers in the vicinity of radiant heat sources. Distances between specific heat sources and sprinklers with different temperature ratings are identified in Table 10.

All sprinklers within the same residential compartment shall have the same temperature rating except where required by 14.3 and Table 10 for a specific location.

Sprinklers installed near specific heat sources that are identified in Table 10 shall be of the temperature rating indicated.

Table 10 – Minimum distances between specific heat sources and sprinklers with ordinary and intermediate temperature ratings

	Minimum distance from edge of heat source to ordinary temperature sprinkler	Minimum distance from edge of heat source to intermediate temperature sprinkler
Heat Source	mm	mm
Side of open or recessed fireplace	900	300
Front of recessed fireplace	1500	900
Coal- or wood-burning stove	1000	300
Kitchen range	450	225
Wall oven	450	225
Hot air flues	450	225
Uninsulated heat ducts	450	225
Uninsulated hot water pipes	300	150
Side of ceiling- or wall-mounted hot air diffusers	600	300
Front of wall-mounted hot air diffusers	900	450
Hot water heater or furnace	150	75
Light fixture		
0 W–250 W	150	75
250 W–499 W	300	150

14.4 Sprinkler rosettes

Rosettes shall not be used to support ceilings or other structures.

Rosettes shall be used and installed according to the manufacturer’s specification. All recessed rosettes and all flat plate non-metallic rosettes must be specifically investigated together with the sprinkler with which they are being used and shall be in accordance with prNS INSTA 900-2.

15 Valves

15.1 Control valve set

15.1.1 Control Valve set for Type 1 and Type 2 buildings

Each installation shall be provided with the means to perform the following functions:

- isolate the system from the supply
- prevent the backflow
- provide a signal in the event of water flow
- device for test the signal
- draining of the system
- Type “B” and “C” pressure gauge

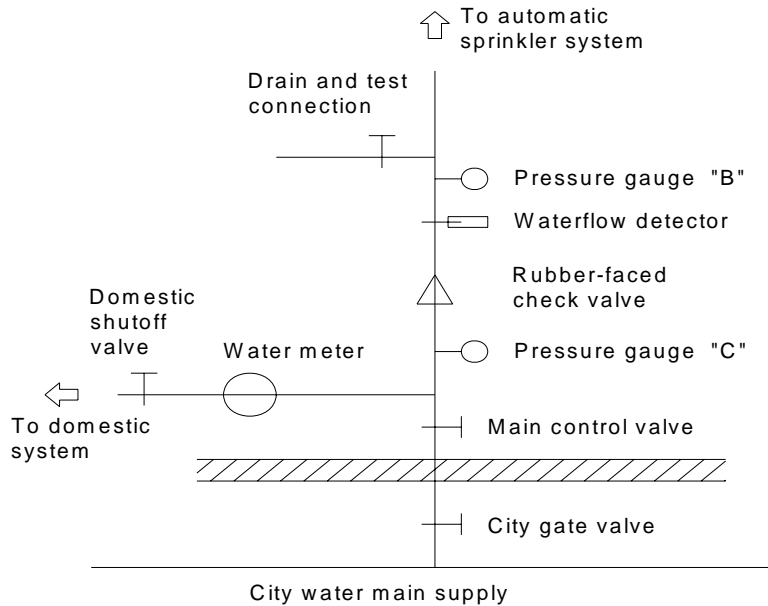

Figure 9 – Control valve set for Type 1 and Type 2 buildings

15.1.2 Control Valve set for Type 3 buildings

When the residential sprinkler system is a part of a system which also includes installations in accordance with EN 12845, then each installation shall have a control valve set in accordance with EN 12259-2 or EN 12259-3. For pre-action installations the control valve set shall be in accordance with the manufacturer’s specification.

When the design criteria for the entire system satisfies Table 2 for a Type 3 building, then the control valve set may be in accordance with 15.1.1.

15.2 Stop valves

All stop valves which may cut off the water supply to the sprinklers shall:

- close in the clockwise direction;
- be fitted with an indicator that clearly shows whether it is in the open or closed position;
- be secured in the right position by a strap and padlock or secured in an equivalent manner.

Stop valves may not be installed downstream of the control valve set except as specified in this guideline.

Care shall be taken to ensure that all stop, test, drain and flushing valves are suitable for the system pressures.

15.3 Drain requirements

The installation shall be equipped with the necessary means to completely drain the systems.

15.4 Test valves

15.4.1 Alarm and pump start test valves

The installation shall be designed such that the following tests can be conducted:

- a) the hydraulic alarm and any electric alarm switches;
- b) the automatic pump starting device, if installed.

15.4.2 Remote test valves for type 3 buildings

A test facility shall be provided, incorporating a test valve with any associated fittings and pipework, delivering a flow equivalent to the discharge from a single sprinkler, connected at the hydraulically most remote location on a distribution pipe.

15.5 Pressure gauges

15.5.1 General

Pressure gauge scale divisions shall not exceed:

- a) 0,2 bar for a maximum scale value less than or equal to 10 bar;
- b) 0,5 bar for a maximum scale value greater than 10 bar.

The maximum scale value shall be of the order of 150% of the maximum pressure.

15.5.2 Water supply connections

Each pump supply shall be fitted with a damped pressure gauge on the supply pipe immediately downstream of the outlet non-return valve and upstream of any outlet stop valve.

15.5.3 Control valve set

A pressure gauge shall be fitted at each of the following locations:

- a) immediately upstream of each control valve set, ('B' gauge);
- b) immediately downstream of each control valve set, ('C' gauge);
- c) immediately downstream of each alternate or dry subsidiary control valve set, but upstream of any stop valve.

The B gauge on dry alarm valves shall have an indicator showing the maximum pressure attained.

15.5.4 Removal

Means shall be provided to enable each pressure gauge to be removed without interruption of the water or air supply to the installation.

16 Alarms and alarm devices

16.1 General

16.1.1 Alarm

In the event of water flow the resulting signal shall be audible as a minimum in the dwelling unit where the operated sprinklers are located. The alarm volume shall be at least 65 dB(A) and at least 10 dB(A) higher than normal background noise. Where people are sleeping the alarm volume shall be at least 75 dB(A) at bedside. In rooms with hearing impaired people other equivalent alarm devices shall be used.

16.1.2 Monitoring

The monitoring devices shall be electrically connected according to 16.1 and installed at an accessible location on the premises, where the following indications and warnings shall be given:

- a) audible devices and red visual indicators to indicate that water is flowing into the installation;
- b) audible devices and red visual indicators to indicate that water is flowing into one or more zones.

Facilities shall be provided at the indicator panel for silencing the audible alarms but the visual indicators shall continue to operate until the installation is restored to the normal standby condition.

Any change in the panel alarm or fault indication after the audible alarm has been silenced shall cause it to resume sounding until it is again silenced or the panel reset to the normal standby condition.

NOTE The authority may require additional alarm devices.

16.2 Alarms and alarm devices, type 2 and 3 buildings

Two pressure switches shall be connected to the alarm pipe line, each shall be capable of being tested independently. The pressure switches shall be connected to a remote station according 16.4.

16.3 Electrical water flow and pressure switches

16.3.1 General

Electrical devices to detect the operation of sprinkler systems shall be either water flow switches conforming to EN 12259-5 or pressure switches suitable for the intended use.

16.3.2 Water flow alarm switches

Water flow alarm switches shall only be used in wet installations. A means for testing the switches shall be provided.

16.3.3 Dry and pre-action systems

Each installation shall be provided with a low air/gas pressure alarm, to provide a visual and audible warning.

16.4 Alarm connection to alarm receiving centre

For Type 1 and 2 buildings, the solution for alarm transmission shall be decided by the authorities. In any case, it is recommended that alarm and fault signals are transmitted to a local manned centre.

For type 3 buildings the system described below shall be fulfilled.

Equipment for transmitting the signals shall be tested and certified in accordance with:

- EN 54 part 2 for the control and indicating equipment (c.i.e.)
- EN 54 part 4 for the power supply
- EN 54 part 11 for the manual call point
- EN 54 part 21 for alarm and fault transmission equipment

The connection from the c.i.e to the alarm receiving centre shall be monitored in its full length. In case of fault on the connection, a fault condition signal shall be given preferable at both the protected building (local manned centre) and at the alarm receiving centre.

The fire alarm signal shall in case of fire be indicated at the c.i.e and at place in the protected buildings where the signal will be noticed (local manned centre).

In case of fault condition the signal shall be indicated at the c.i.e and at place in the protected buildings where the signal will be noticed (local manned centre).

The electrical connection between the manual call point and the c.i.e shall be monitored in its full length.

The electrical connection between flow switches/alarm pressure switches and the c.i.e shall be monitored in its full length.

The manual call point shall be installed in order to the testing of the system and in order to activate the alarm condition if the sprinkler system is out of order.

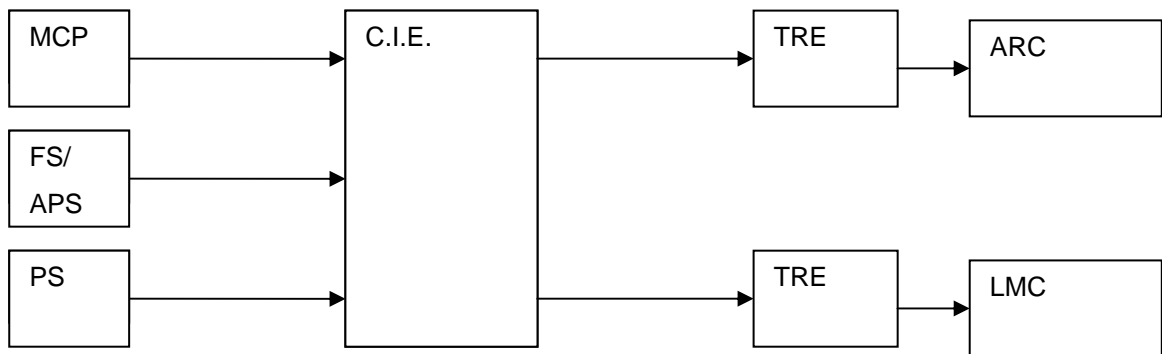

Key	
MCP	Manual Call Point
FS/APS	Flow Switch/Alarm Pressure Switch
C.I.E.	Control and Indicating Equipment
PS	Power Supply
ARC	Alarm Receiving Centre
LMC	Local Manned Center
TRE	Transmission Routing Equipment

Figure 10 — Main elements of an alarm transmission system

17 Pipework

17.1 Pipe system

17.1.1 Installation

Adequate precautions shall be taken to prevent mechanical damage to piping. All piping shall be installed according to relevant national standards. The manufacturer shall provide documentation confirming that the pipe system is suitable for its purpose.

Range pipes shall be connected to the side or top of distribution pipe.

The attachment of pipework to or the adaptation of structural members shall be done in such a way that the structural integrity of the building is not compromised.

17.1.2 Pipework in metal

Pipes and fittings in metal shall be installed according to EN 12845. Pipes shall be installed in accordance with the manufacturer's specifications and shall have sufficient corrosion resistance. For dry and pre-action systems the pipes and fittings shall be hot dipped galvanized, copper or stainless steel.

17.1.3 Pipework in plastic

Pipes and fittings in plastic shall be installed according to manufacturer's specification.

17.1.4 Drainage

Means shall be provided to enable all the pipework to be drained.

17.2 Pipe supports

17.2.1 General

Pipe supports shall be used in accordance to EN 12845. For pipework in plastic the pipe supports shall be according to manufacturer's specification.

18 Signs, notices, and information

18.1 Block plan

18.1.1 General

For all other buildings than type 1, a block plan of the premises shall be placed close to a main entrance or elsewhere, where it can readily be seen by the fire brigade or others responding to an alarm. The plan shall show:

- a) the installation number and the location of the corresponding control valve set;
- b) by means of colour shading or hatching the area covered by each installation and indication of routes through the premises to those areas;
- c) the location of any subsidiary stop valves.

18.2 Signs and notices

18.2.1 Location plate

A location plate of weather-resistant material and lettering shall be fixed on the outside of the external wall as close as practical to the entrance nearest the control valve set(s). For dwellings this plate may be fixed inside the main entrance. The plate shall bear the wording in white letters on a red background:

'SPRINKLER STOP VALVE'

18.2.2 Signs for stop valves

A sign shall be fitted close to the main and any subsidiary stop valves bearing the words

'SPRINKLER CONTROL VALVE'

Where the stop valve is enclosed in a room with a door the sign shall be fixed on the outside of the door, and a second sign, bearing the words 'Keep locked shut', shall be fixed on the inside of the door.

18.2.3 Control valve set

18.2.3.1 General

Where the residential sprinkler system comprises more than one installation each control valve set shall be prominently marked with the number identifying the installation it controls.

18.2.3.2 Installation information

In each installation a durable notice shall be fixed to the rise pipe next to the control valve set. The notice shall include the following information:

- a) the installation number;
- b) the design requirements (area of operation and density of discharge);
- c) the pressure-flow requirement.

18.2.4 Suction and booster pumps

An installer's data sheet shall be displayed beside the pump, giving the following information:

- a) the pump supplier's data sheets;
- b) a schedule listing the technical data specified in 4.3.4.4;
- c) a copy of the installer's pump characteristics sheet, similar in presentation to Figure 3;
- d) the pressure loss, at flow $Q_{max.}$, between the pump outlet and the most hydraulically remote control valve set.

18.2.5 Electric switches and control panels

18.2.5.1 Alarms transmitted to the fire brigade

Where water flow into an installation initiates an automatic alarm to the fire brigade, a notice to that effect shall be fixed adjacent to the alarm test valve(s).

18.2.5.2 Pumpset

Any alarms from the residential sprinkler pump set shall be appropriately marked at both the pump controller and the local manned center.

Manually operated shut-down mechanism shall be labelled as follows:

'SPRINKLER PUMP SHUT-OFF'

18.2.5.3 Electric motor driven fire pump

Each switch on the dedicated power feed to an electric sprinkler fire pump motor shall be labelled as follows:

**'SPRINKLER PUMP MOTOR SUPPLY -
NOT TO BE SWITCHED OFF IN THE EVENT OF FIRE'**

18.2.6 Testing and operating devices

All valves and instruments used for testing and operation of the system shall be appropriately labelled. Corresponding identification shall appear in the documentation.

19 Commissioning and acceptance tests and periodic inspection

19.1 Commissioning tests

19.1.1 Pipework

19.1.1.1 All pipework

All installation pipework shall be hydrostatically tested for no less than 2 h, to a pressure of no less than 15 bar, or 1,5 times the maximum pressure to which the system will be subjected, (both measured at the installation control valves), whichever is the greater.

19.1.1.2 Dry pipework

Dry pipework shall be tested pneumatically to a pressure of no less than 2,5 bar for no less than 24 h. Any leakage that results in a loss of pressure greater than 0,15 bar for the 24 h shall be corrected.

19.1.2 Water supplies

Water supplies shall be tested once as specified in 8.4, and diesel engine driven pumps shall be tested as specified in chapter 20.

19.2 Completion certificate and documents

The installer of the system shall provide the user with the following:

- a) a completion certificate stating that the system complies with all appropriate requirements of this guideline giving details of any deviation from the requirements;
- b) a complete set of operating instructions and "as-built" drawings including identification of all valves and instruments used for testing and operation and a user's programme for inspection and checking (see 20.1).

20 Inspection, testing and maintenance

20.1 General

The user shall carry out a programme of inspection and checks, arrange a test, service and maintenance schedule and keep records including a logbook which shall be held on the premises.

Before freezing weather each year, check the specific gravity of the antifreeze solution (if applicable) by a hydrometer with a scale having 0.002 subdivisions and add concentrated liquid if needed.

The user shall arrange for the test, service and maintenance schedule to be carried out under contract by the system installer or a similarly qualified company.

After an inspection, check, test, service or maintenance procedure the system, and any automatic pumps, pressure tanks and gravity tanks shall be returned to the proper operational condition.

NOTE If appropriate, the user should notify interested parties of the intent to carry out tests and/or of the results.

The user shall carry out a programme of inspections and checks according to Table 11.

Table 11 – Requirements for maintenance

Type of building	Requirements for maintenance
1	Inspections, test and maintenance of the system shall be performed at least once a year and according with manufacturer's specification
2	According to 20.3
3	According to EN 12845

NOTE In the case the residential sprinkler system is installed to compensate for other fire protection methods, the minimum requirements shall be according to EN 12845.

20.2 Precautions while carrying out work

The owner shall notify all parties of interest of the intent to carry out tests and/or shut down of the sprinkler system.

NOTE See annex D for precautions to be taken while the system is not operational or after a sprinkler operation.

20.3 Requirements for type 2 buildings

The installer shall provide to the owner instructions on inspecting, testing, and maintaining the system.

For residential sprinkler systems in type 2 buildings, inspection, testing and maintenance shall be done according to chapter 20 in EN 12845 or the following program.

20.3.1 Quarterly program

A minimum quarterly program shall include the following:

1. Visual inspection of all sprinklers to ensure against obstruction of spray or damages of the sprinkler head. Special attention should be given to ensure that sprinklers are not painted either at the time of installation or during subsequent redecoration.
2. Inspection of all valves to ensure that they are open.

3. Testing of all waterflow devices.
4. Testing of the alarm system, where installed. If the alarm system is connected to a remote station such as a fire department, notification should be made prior to the test.
5. Operation of pumps, where employed (shall be done according to EN 12845).
6. Checking of the pressure of air used with dry systems.
7. Checking of water level in tanks, where employed.

All work on the sprinkler system (replacement of sprinkler heads, pipes et.c) shall be done by a competent person

21 Third party inspection

21.1 General

The system shall be inspected by a third party according to Table 12:

Table 12 – Frequency for third party inspections

Type of building	Frequency for third party inspections
1	According to the authority
2	According to the authority
3	After commissioning and then on an annual basis

NOTE In the case the residential sprinkler system is installed to compensate for other fire protection methods, the third party inspection shall be carried out after commissioning and then on an annual basis.

21.2 Inspection procedures for type 2 and 3 buildings

21.2.1 The third party inspection shall be carried out after commissioning is completed.

21.2.2 The third party inspection shall cover control of documentation and the function of the system. The third party inspection shall include practical testing of functions and signals but may exclude tests that could result in unforeseen or damaging operation if these tests are verified in the commissioning procedure.

21.2.3 The third party inspection body shall provide the user with a third party inspection certificate or report that states that the system complies with all appropriate requirements of this guideline giving details of any deviation from the requirements.

Annex A (normative)

Zoning

A.1 General

This annex specifies the zoning requirements of residential sprinkler systems.

A.2 Requirements for zoned installations

A.2.1 Extent of zones

No zone shall:

- a) include more than 500 sprinklers;
- b) include more than one floor within the building

A.2.2 Zone stop valves

Each zone shall be independently controlled by a single zone stop valve, installed in a readily accessible position in the zone it controls. Each valve shall be secured open and be labelled to identify the area of protection it controls. The zone stop valve shall be provided with devices to monitor the status of the valve (i.e. either fully open or not fully open).

A.2.3 Zone alarm device

Immediately downstream of the zone stop valve an alarm device, capable of detecting a flow equal to or greater than that from any single sprinkler, shall be installed in order to forward an alarm signal.

A.2.4 Zone test and drainage facilities

Permanent test and drainage facilities shall be provided immediately downstream of the water flow alarm switch on each zone. The test facility shall simulate operation of any single sprinkler head. Adequate provision shall be made for the disposal of waste water.

Annex B **(normative)**

Sprinkler systems monitoring

Type 1 and 2 buildings

For type 1 and 2 buildings, decision to have the sprinkler system monitored or not shall be decided by the authorities.

NOTE If the sprinkler systems are to be monitored, the system described below should be fulfilled.

Type 3 buildings

Sprinkler systems shall be monitored as described below.

B.1 General

The aim of monitoring sprinkler systems is the continuous supervision of the main functions of the system, i.e. those whose failure might impair the correct automatic operation of the system in case of fire, and the raising of a supervisory alarm to allow corrective measures to be taken. This annex specifies requirements, which are additional to those elsewhere in the guideline. They shall be complied with whenever monitoring is specified.

All devices used for monitoring shall have at least IP 54 protection as specified in EN 60529 and be connected to a common supervisory alarm device.

All signalling and alarm circuits shall be fully supervised and a fault alarm shall be given in the event of short or open circuit where this corresponds to a fault.

Control and indicating equipment shall be in accordance with any provision valid in the country in use.

B.2 Functions to be monitored

B.2.1 General

The following shall be monitored in addition to all monitoring requirements specified elsewhere in this standard (see Annex C):

B.2.2 Stop valves controlling water flow to sprinklers

The position of all normally open stop valves the closing of which could prevent water flowing to the sprinklers, including water supply valves, control valve sets, subsidiary valves and sectional valves. An indication shall be given whenever the valve is less than fully open.

B.2.3 Other stop valves

The position of all normally open stop valves the closing of which could prevent the correct operation of an alarm or indicating device, e.g. pressure switch, hydraulic alarm, flow switch. An indication shall be given whenever the valve is less than fully open.

B.2.4 Liquid levels

All critical liquid levels, including water storage tanks and engine fuel tanks. An indication shall be given before a water storage level drops more than 10% below its nominal fill level, or before a fuel level drops more than 25%

below its nominal fill level. In the case of pressure tanks a further indication shall be given before the level reaches 10% above its nominal fill level.

B.2.5 Pressures

Pressures, including at water supplies and downstream of all dry and alternate control valve sets. On town main supplies an indication shall be given if the static pressure drops below the calculated running pressure. In all other cases an indication shall be given when the static pressure drops by more than 20% below the tested level.

B.2.6 Electrical power

The power supply to electrical pump sets or other critical electrical equipment. An indication shall be given if one or more phases fail at any point in the main supply, or in the control circuit or an electric or diesel pump controller or any other critical control equipment.

B.2.7 Temperature

Minimum temperature of the sprinkler valve and pump room. An indication shall be given if the temperature drops below the minimum required level.

Annex C (normative)

Transmission of alarms

Type 1 and 2 buildings

For type 1 and 2 buildings, decision whether to alarms from the sprinkler system are to be transmitted or not shall be decided by the authorities.

NOTE If alarms from the sprinkler systems are to be transmitted, the system described below should be fulfilled.

Type 3 buildings

Alarms from sprinkler systems shall be transmitted as described below.

C.1 Functions to be monitored

Alarms, as specified in this guideline, shall be connected to an alarm panel in the sprinkler control room or pump room and be transmitted onwards depending on the importance of the alarm. Alarms shall be transmitted to a permanently attended location, on or off the premises, or to a responsible person in such a way that appropriate action can be taken immediately. Fire alarm condition shall be transmitted as described in 16.4.

C.2 Alarm levels

Signals such as water flow indication, which could be indicative of a fire, shall be shown as fire alarms (Alarm level A in Table C.1). Technical faults such as a power failure, which could prevent the system operating correctly in case of fire, shall be shown as trouble alarms (Alarm level B in Table C.1).

To be revised when the main document is finished

Table C.1 — Type of alarm for transmission

Alarm	Clause	Alarm type
Water flow detection	16.3	A
Electric pump set - on demand - start failure - running - power not available	10.8.6.1	B B A B
Diesel pump set - automatic mode off - start failure - running - fault in controller	10.9.11	B B A B
Trace heating circuits	11.1.2	B
Low pressure - dry pipe and pre-action systems	B.2.5	B
Zoned systems - open control valve - partially closed control valve - partially open subsidiary valve - low mains pressure - water flow in installation - water flow in zone	A.2.2 A.2.3	B B B B A A
Monitored sprinkler systems - partially closed stop valves - liquid levels - low pressure - power failure - low temperature in pump room	Annex B	B B B B B

Annex D **(informative)**

Precautions and procedures when a system is not fully operational

D.1 Minimizing the effects

Maintenance, alterations and repair of systems which are not fully operational should be carried out such as to minimize the time and extent of non-operation.

When an installation is rendered inoperative the user should implement the following measures:

- a) the authorities and any central monitoring station should be informed as well as the affected residents in the building;
- b) supervisory staff in the areas affected should be notified and the area should be patrolled continuously;
- c) any hot work or other work that may cause danger for fire shall be avoided or subject to a permit system;
- d) other precautions shall be made, for example closing of fire doors and fire shutters, checking the number and readiness of portable fire extinguishers etc;
- e) as much as possible of the installation should be retained in an operative condition by blanking off pipework feeding the part or parts where work is taking place;
- f) any pump which is out of commission should be isolated by means of the valves provided;
- g) where possible parts of installations should be reinstated to provide some protection overnight by using blinders and blanks within the pipework; the blinders and blanks should be fitted with visible indicator tags numbered and logged to aid timely removal.

D.2 Planned shut-down

Only the user should give permission for a residential sprinkler installation or zone to be shut down for any reason other than an emergency.

Before a system is wholly or partly shut down every part of the premises should be checked to ensure that there is no indication of fire.

Where premises are subdivided into separate occupancies constituting buildings in communication or at risk, protected by common sprinkler systems or installations, all occupiers should also be advised that the water is to be turned off.

Particular attention should be given to situations where installation pipework passes through walls or ceilings.

D.3 Unplanned shut-down

When an installation is rendered inoperative as a matter of urgency or by accident, the precautions in D.1 should be observed as far as they are applicable with the least possible delay. The authorities concerned should also be notified as soon as is possible.

D.4 Action following sprinkler operation

Following shut-down after operation of an installation, the operated sprinkler heads should be replaced by heads of the correct type and temperature rating, and the water supply restored. Unopened sprinklers around the area in which operation took place should be checked for damage by heat or other cause and replaced as necessary.

The water to an installation or zone of an installation that has operated should not be shut off until all fire has been extinguished.

The decision to shut down an installation or zone which has operated because of a fire should be taken only by person with the competence to ensure that the fire is fully extinguished.

Components removed from the system should be retained by the user for possible examination by an authority.

Annex E
(normative)

Inspection of pipes and sprinklers

After 25 years the pipes and the sprinklers shall be inspected. In case of dry pipe or pre-action system the pipes shall be checked after 10 years.

The pipework shall be thoroughly flushed out and hydrostatically tested to a pressure equal to the maximum static pressure or 12 bar, whichever is the greater.

The pipework shall be internally and externally inspected. At least one metre length of range pipe shall be inspected per 100 sprinklers. Two pipe sections of at least one metre length of each pipe diameter shall be inspected.

All defects which might adversely affect the performance of the system shall be eliminated.

In the case of wet pipe systems at least one sprinkler installation per building shall be checked. If several wet control valve sets are installed in one building only 10% need to be inspected. In the case of dry pipe systems, such a reduction of the number of installations to be checked is not allowed.

A number of sprinklers shall be removed and inspected. Table E specifies the scope of sampling as a function of the total number of sprinklers installed.

Table E – Number of sprinklers to be inspected

Total number of sprinklers installed	Number of sprinklers to be inspected
≤ 5 000	20
> 5 000	40

The sprinklers shall be evaluated for the following:

- a) Operation
- b) Operation temperature
- c) Variation of K-factor
- d) Spray obstacles
- e) Lodgement
- f) Thermal sensitivity

Annex F (informative)

New technology

During preceding the preparation of this guideline new technologies suitable for residential occupancies could be developed and available to the market. Nothing in this guideline is intended to restrict the use of this new technology or alternative arrangements.

Technology not covered by this guideline should only be used in accordance with the results of large scale fire test or accepted test methods and where the design criteria are fully acceptable to the authorities involved.

It is intended that such new technology will be included in the future editions of these guidelines.